

Data Book

TRCS2-G05-Z 0211 - 1154_201902_EN HFC R513A
ELCA_Engine ver.4.1.1.0



TRCS2-G05-Z 0211 - 1154

| High efficiency chiller, air source for outdoor installation



(The photo of the unit is indicative and may vary depending on the model)

- VERY HIGH EFFICIENCY
- VERSION 'CA-E' AVAILABLE
- EXTREMELY SILENT OPERATION
- LOW INRUSH CURRENTS



CERTIFICATIONS

Product certifications



Voluntary product certifications



This company participates in the Eurovent Certification Programme. The products are listed in the Directory of certified products.

The Eurovent certificate, for the applicable units, refers to products with cooling capacity up to 600 kW, voluntarily extended up to 1500 kW, for air-cooled models and water-cooled models.

System certifications



Climaveneta S.p.A.:

Quality System complying with the requirements of UNI EN ISO9001:2008 regulation

Environmental Management System complying with the requirements of UNI EN ISO14001:2004 regulation

INDEX**TRCS2-G05-Z 0211 - 1154**

1.1	PRODUCT FEATURES	pg.1.1.1 / 1.1.1
2.1	PRODUCT PRESENTATION	pg.2.1.1 / 2.1.1
3.1	INCIPIT	pg.3.1.1 / 3.1.1
4.1	UNIT STANDARD COMPOSITION	pg.4.1.1 / 4.1.2
5.1	OPTIONS	pg.5.1.1 / 5.1.5
6.1	GENERAL TECHNICAL DATA	pg.6.1.1 / 6.1.6
7.1	TECHNICAL DATA SEASONAL EFFICIENCY IN COOLING (EN14825 VALUE)	pg.7.1.1 / 7.1.0
8.1	OPERATING LIMITS	pg.8.1.1 / 8.1.3
9.1	HYDRAULIC DATA	pg.9.1.1 / 9.1.2
10.1	ELECTRICAL DATA	pg.10.1.1 / 10.1.3
11.1	FULL LOAD SOUND LEVEL	pg.11.1.1 / 11.1.3
12.1	DIMENSIONAL DRAWINGS	pg.12.1.1 / 12.1.3
13.1	HYDRONIC GROUP	pg.13.1.1 / 13.1.6

Liability disclaimer

The present publication is drawn up by of information only and does not constitute an offer binding upon Mitsubishi Electric Hydronics & IT Cooling Systems S.p.A.

Mitsubishi Electric Hydronics & IT Cooling Systems S.p.A. has compiled the content of this publication to the best of its knowledge. The data contained herein are subject to change without notice. Mitsubishi Electric Hydronics & IT Cooling Systems S.p.A. explicitly rejects any liability for any direct or indirect damage, in the broadest sense, arising from or related to the use and/or interpretation of this publication. All content is copyrighted by Mitsubishi Electric Hydronics & IT Cooling Systems S.p.A.

The units highlighted in this publication contain R513A [GWP₁₀₀ 631] fluorinated greenhouse gases.



Functions

 COOLING Cooling

Refrigerant

 R513A R513A

Compressors

 CENTRIFUGAL Centrifugal compressor

Fan

 AXIAL Axial fan

Exchangers

 FLOODED Flooded evaporator

Other features right position

 ENERGY CLASS Energy Class A

Other features

 EUROVENT CERTIFIED PERFORMANCE Eurovent

 VPF VARIABLE PRIMARY FLOW VPF

 VSPEED VARIABLE SPEED DRIVE VSpeed

 GREEN CERTIFICATION RELEVANT GREEN Certification relevant

1.1 PRODUCT FEATURES

1.2 GREEN CERTIFICATION RELEVANT

Mitsubishi Electric Hydronics & IT Cooling Systems S.p.A., as a major player in the world HVAC market and a leading manufacturer of energy efficient, sustainable HVAC solutions, recognizes and supports the diffusion of green certification systems, as an effective way to deliver high performance buildings and improve the quality and the sustainability of the built environment.

Since the first certification system was introduced at the beginning of the 1990s, the demand for certified buildings has grown considerably, as well as the number of standards, rating and certification programs. Operating worldwide Mitsubishi Electric Hydronics & IT Cooling Systems S.p.A., has extensive experience with many of them and is active member of Green Building Council Italy.

Mitsubishi Electric Hydronics & IT Cooling Systems S.p.A., commitment to develop responsible and sustainable HVAC solutions, is reflected by a full range of premium efficiency products and systems, designed with special care to improve building energy performance ratings, according to major certification protocols, including LEED, BREAM, GREENSTAR, BCA, NABERS, DNGB, HQE and BEAM.

To find out more about how our products contribute to enhanced green certification rating and energy performance of a building, please refer to: <https://www.melcohit.com/GLOBAL/Company/Green-Certifications/QR%20code/>



2.1 PRODUCT PRESENTATION

Outdoor unit for the production of chilled water featuring oil-free centrifugal compressor, with R513A, axial-flow fans, condensing coil with copper tubes and aluminium fins, shell and tube flooded evaporator and electronic regulation valve. Base and supporting structure and panels are of galvanized epoxy powder coated steel with increased thickness. Flexible and reliable unit; it easily adapts itself to different thermal load conditions thanks to the precise thermoregulation together with the use of inverter technology. The compressor is radically innovative: magnetic bearings and digital rotor speed control allow partial load efficiency levels to be reached that were hitherto impossible.

2.3 VERY HIGH EFFICIENCY

Very high efficiency at full and partial load, to top market levels, thanks to adopted technological solutions: large capacity modulation and expanded exchanger, offering minimum running costs of the unit in real working conditions.

2.4 VERSION 'CA-E' AVAILABLE

The version 'CA-E' is characterized by efficiency beyond the 'Class A' for Eurovent. The technological choices adopted assure the minimization of operating costs and therefore a quick payback time.

2.5 EXTREMELY SILENT OPERATION

As result of a systematic design oriented to minimize the noise level, XL version's units give the best compromise between silence and efficiency on the market.

2.6 LOW INRUSH CURRENTS

Reduced breakaway starting currents thanks to the revolutionary centrifugal compressor.

TRCS2-G05-Z / D / SL-CA-E 1154

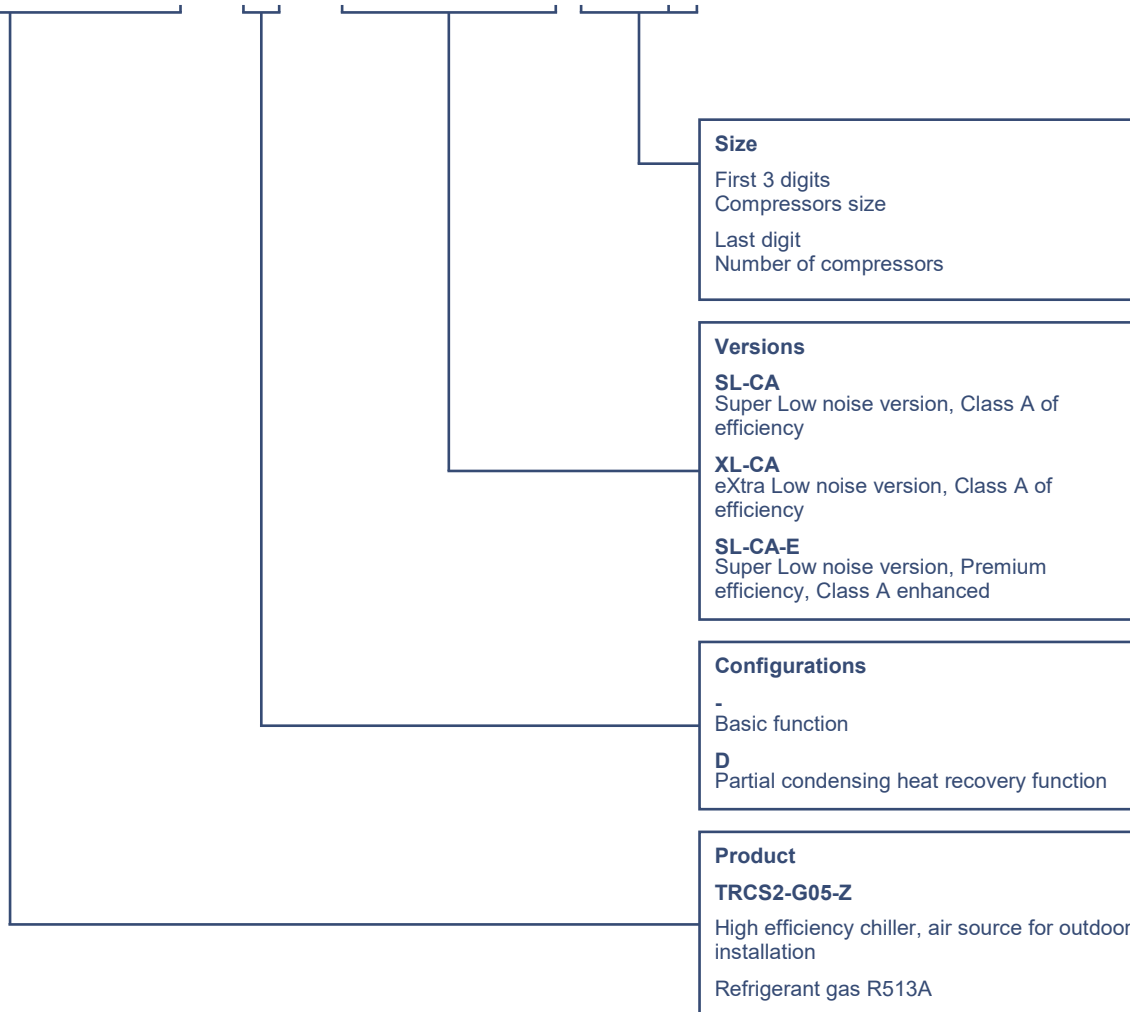

4.1 UNIT STANDARD COMPOSITION

4.2 High efficiency chiller, air source for outdoor installation

Outdoor unit for the production of chilled water featuring oil-free centrifugal compressor, with R513A, axial-flow fans, condensing coil with copper tubes and aluminium fins, shell and tube flooded evaporator and electronic regulation valve. Base and supporting structure and panels are of galvanized epoxy powder coated steel with increased thickness. Flexible and reliable unit; it easily adapts itself to different thermal load conditions thanks to the precise thermoregulation together with the use of inverter technology. The compressor is radically innovative: magnetic bearings and digital rotor speed control allow partial load efficiency levels to be reached that were hitherto impossible.

- The unit is supplied fully refrigerant charged and factory tested. On site installation only requires power and hydraulic connection.

4.3 Structure

Base and frame in galvanized steel. The supporting frame are polyester-painted for the highest resistance to external factors: surfaces' hue and brightness are preserved. In silenced versions, pipes and compressors' box are covered with an acoustic layer to reduce global noise emissions.

4.4 Refrigerant circuit

Unit designed with up to 2 compressors in a single refrigerant circuit optimizing the heat exchange's process, especially in part load mode, without any risk in the proper management of oil which is, in this series, completely absent.

Standard components of the refrigerant circuits are:

- electronic expansion valve
- high and low pressure safety valve with visualization of the pressure's level and the rotational speed directly from the controller's interface
- on-off cock on the compressor's suction and delivery line and on the refrigerant line
- filter on compressor's inlet
- drier filter with replaceable cartridge
- refrigerant line sight glass with humidity indicator
- safety switching device for limiting the pressure
- Economizer is adopted in sizes of the ultra high efficiency version SL-CA-E.

4.5 Compressor

Two stage, variable speed, centrifugal compressor with aluminium impellers, designed requiring no oil for lubrication. Compressor constructed with cast aluminium casing and high-strength thermoplastic electronics enclosures. Compressor provided with radial and axial magnetic bearings to levitate the shaft thereby eliminating metal to metal contact, and thus eliminating friction and the need for oil. Each bearing position is sensed by position sensors to provide real-time repositioning of the rotor shaft, controlled by the on-board digital electronics. Compressor speed is reduced as condensing temperature and/or heat load reduces, optimizing energy performance through the entire range.

Continuous modulation is possible thanks to the integrated inverter. Signals from the compressor controller determine the inverter output frequency, voltage and phase, thereby regulating the motor speed. In case of power failure, the compressor is capable of allowing for a normal de-levitation and shutdown. Inlet Guide Vanes is built-in to further trim the compressor capacity in conjunction with the variable-speed control, to optimize compressor performance at low loads.

The compressor is provided with a direct drive, high efficiency, permanent-magnet synchronous motor powered by pulse-width-modulating (PWM) voltage supply. Motor cooling is by liquid refrigerant injection, directly managed by the compressor. A non-return valve on the discharge port of the compressor is installed to protect against backflow of refrigerant during coastdown; a thermal protection protects against over-currents while a soft-charge device reduces in-rush starting current under 2 amps.

4.6 Plant side heat exchanger

Shell and tube heat exchanger, fully designed and manufactured by MEHITS, working as flooded type evaporator, with water flowing inside the pipes and refrigerant flowing in the shell side. The steel shell is insulated with a foamed polyethylene closed-cell mat of 9 mm thickness and a thermal conductivity of 0,033 W/mK at 0°C. The copper pipes are internally and externally grooved in order to improve the heat exchange. Integrated system to avoid liquid entrainment and to protect the compressor against the risk of liquid suction. A differential pressure switch is fitted in order to control the water flow while the unit is working, avoiding the risk of ice generation. An electric heater, operating when antifreezing mode is active, is present on the shell. The pipes' flooding is controlled by an electronic expansion valve, managed by proprietary logics to guarantee the proper refrigerant flow and the complete flooding

of pipes in all conditions of compressors' load. The heat exchanger complies with PED standards, concerning the operating pressures.

4.7 Source side heat exchanger

Condensing coil made with copper tubes and aluminium fins. The aluminium fins are spaced to guarantee the best heat exchange efficiency. The lower part of the exchanger works as a subcooling circuit increasing the cooling capacity.

4.8 Fan section source side

Elettroventilatori assiali con grado di protezione IP54 e classe 'F' di isolamento, a rotore esterno, con pale profilate in alluminio pressofuso, alloggiati in boccagli a profilo aerodinamico, completi di protezione antinfortunistica. Motore elettrico a 6 poli provvisto di protezione termica incorporata.

Dispositivo basse temperature Velocità Variabile (DVV) per il controllo della condensazione mediante regolazione della velocità di rotazione tramite gradini di tensione (autotrasformatore).

Le taglie della versione ultra efficiente SL-CA-E impiegano ventilatori a commutazione elettronica EC. Il motore brushless, governato da apposito controllore, regola in modo continuo il numero di giri del ventilatore minimizzando il consumo energetico, i disturbi elettromagnetici e gli assorbimenti di corrente anche in fase di avviamento.

4.9 Electrical and control panel

Electrical and control panel built to EN60204-1 and EC204-1 standards, complete with:

- electronic controller
- control circuit transformer
- general door lock isolator
- power circuit with electric bus bar distribution system
- EMC filter and reactor on the compressor's power circuit
- fuses for compressors and fans
- terminals for cumulative alarm block
- remote ON/OFF terminals
- spring-type control circuit terminal board
- auxiliary 4-20mA analogue input
- relays for remote pump(s) activation for both circuits (only for units without hydronic pumps)

4.10 Certification and applicable directives

The unit complies with the following directives and relative amendments:

- EUROVENT Certification program
- CE Declaration of conformity certificate for the European Union
- EAC Product quality certificate for Russian Federation
- SAFETY QUALITY LICENCE Product quality certificate for Popular Republic of China
- M&I Product quality certificate for Australia and New Zealand
- Electromagnetic compatibility EN 61000-3-4
- Machine directive 2006/42/EC
- PED directive 2014/68/EU
- Low Voltage directive 2006/95/EC
- ElectroMagnetic compatibility directive 2004/108/EC
- ISO 9001 Company's Quality Management System certification
- ISO 14001 Company's Environmental Management System certification

4.11 Tests

Tests performed throughout the production process, as indicated in ISO9001.

Performance or noise tests can be performed by highly qualified staff in the presence of customers.

Performance tests comprise the measurement of:

- electrical data
- water flow rates
- working temperatures
- power input
- power output
- pressure drops on the water-side exchanger both at full load (at the conditions of selection and at the most critical conditions for the condenser) and at part load conditions.

During performance testing it is also possible to simulate the main alarm states.

Noise tests are performed to check noise emissions according to ISO9614.

4.12 Electronic control W3000 TE

The brand new W3000TE controller offers advanced functions and algorithms. The large format keyboard and the wide LCD display favour an easy and safe access to the machine setup and a complete view of unit's status. The assessment and intervention on the unit is managed

UNIT STANDARD COMPOSITION

through a multi-level menu, with selectable user's language. The led icons immediately show the operating status of the circuits, as well as of the fans and of the water pumps (if present). An optional extra is the touch screen interface: 7.0" WVGA colour display with adjustable LED backlight and front USB port. The touch screen technology allows intuitive navigation between the various screens, safe access to the data with a three-level password protection as well as the graphic display of the performance of some monitored measurements.

The diagnostics comprises a complete alarm management system, with "black box" (via PC) and alarm log functions (via display or also PC) for a better analysis of the unit performance.

For the systems made of several units, the adjustment of the resources is performed by optional proprietary devices.

Consumption metering and performance measurement are possible as well. Supervision can be easily developed via proprietary devices or the integration in third party systems by means of the most common protocols as ModBus, Bacnet-over-IP, Echelon LonWorks, Bacnet MS/TP protocols.

Compatibility with the remote keyboard managing up to 8 units.

The presence of the programmable timer allows the creation of an operating profile containing up to 4 typical days and 10 time bands.

The control is characterized by the continuous modulation of the unit capacity, based on PID algorithms and referring to the water delivery temperature.

Optionally (VPF package), capacity modulation can be integrated with hydraulic flow modulation, thanks to inverter-driven pumps and to specific resources for the hydraulic circuit.

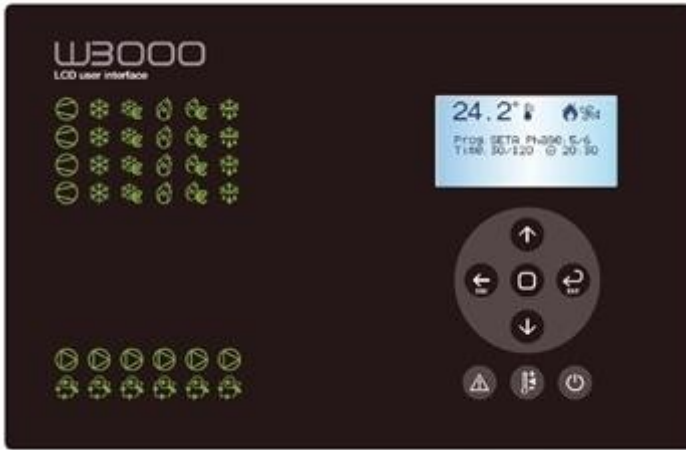

4.13 Versions

/SL-CA - Super Low noise, Class A of efficiency

Super low-noise version, Class A of efficiency as per Eurovent.

Acoustic insulation on the compressors box, on pipes and a low fans' rotational speed gives the minimization of sound emission.

/XL-CA - eXtra Low-noise version, Class A of efficiency

eXtra Low-noise version, Class A of efficiency as per Eurovent. Special acoustic insulation on the compressors box composed by 5 layers, insulation on pipes and a low fans' rotational speed make the sizes of XL version some of the most silent chillers in the market.

/SL-CA-E - Super low noise version, premium efficiency, Class A enhanced

Super Low-noise version, exceeds the Class A of efficiency as per Eurovent.

Acoustic insulation on the compressors box, on pipes and a low fans' rotational speed gives the minimization of sound emission.

Generous sizing of heat exchange surfaces and use of economizers permit the efficiency at full load to be always higher than 3,4 at standard condition.

4.14 Configurations

- , standard unit

Standard unit for production of chilled water

/D, unit with partial heat recovery

Unit for the production of chilled water, equipped with an auxiliary heat exchanger (desuperheater) on the compressor discharge for superheat recovery. The recovered heat is approximately the 20% of the total cooling capacity and can be used for domestic hot water production or other secondary uses, such as the integration of an existing boiler.

5.1 OPTIONS

OPTIONS	DESCRIPTIONS	BENEFITS	AVAILABLE FOR MODELS
1960 PRESSURE RELIEF VALVES			
1961 DUAL RELIEF VALVES WITH SWITCH	Dual relief valve with switch	Allows to unselect a relief valve in order to service the unit avoiding medium or long inoperative periods	ALL
380 NUMBERED WIRING			
381 NUMBERED WIRING ON EL. BOARD	Electrical board wires are identified by numbered labels. The reference numbers are indicated in the unit's wiring scheme.	Facilitate maintainance interventions to the electrical board connections.	ALL
3300 COMPRESSOR REPHASING			
3302 COMPR.POWER FACTOR CORR.0,95	Capacitors on the compressors' power inlet line.	The unit's average cos(phi) increases.	ALL
3410 AUTOMATIC CIRCUIT BREAKERS			
3413 AUTOM.CIRC.BREAKERS FOR FANS	Over-current switch on the fans	In case of overcurrent allows resetting of the switch without the replacement of relative fuses.	ALL
3600 ON/OFF COMPRESSOR SIGNAL			
3601 COMPRESSOR OPERATION SIGNAL	Auxiliary contacts providing a voltage-free signal.	Allows remote signalling of compressor's activation or remote control of any auxiliary loads.	ALL
4180 REMOTE CONNECTION ARRANGEMENT			
4181 SERIAL CARD MODBUS	Interface module for ModBUS protocols.	Allows integration with BMS operating with ModBUS protocol.	ALL
4182 SERIAL CARD FOR LONWORKS	Interface module for Echelon systems.	Allows integration with BMS operating with LonWorks protocols	ALL
4184 SERIAL CARD BACNET MS/TP RS485	Interface module for BACnet protocols.	Allows integration with BMS operating with BACnet protocol.	ALL
4185 SERIAL CARD FOR BACNET OVER IP	Interface module for BACnet OVER-IP protocols.	Allows to interconnect BACnet devices over Internet Protocol within wide-area networks.	ALL
4187 M-Net W3000 INTERFACE KIT	Interface kit for M-Net protocol.	Interface module to allow the integration of the unit with Mitsubishi Electric proprietary communication protocol M-Net.	ALL
6160 AUXILIARY INPUT			
6161 AUXILIARY SIGNAL 4-20mA	4-20 mA analog input	Allows to change the operating set-point according to the value of current applied to the analogue input.	ALL
6162 REMOTE SIGNAL DOUBLE SP	Allows to activate the Energy Saving set-point.	Allows to change the operating set-point according to a remote switch	ALL
6170 DEMAND LIMIT			
6171 INPUT REMOTE DEMAND LIMIT	Digital input (voltage free)	It permits to limit the unit's power absorption for safety reasons or in temporary situation.	ALL
6190 TYPE OF VISUAL DISPLAY			
6195 7 INCH TOUCH SCREEN	The unit is equipped with the Touch interface, with a 7" WVGA colour display and a front USB port (WARNING: with outdoor temperature below 0°C the display response time may visibly increase).	The touch-screen's technology is characterized by an easy-to-access data, and it allows an effective graphical representation of the main figures protecting the access through 3 privilege levels.	ALL

OPTIONS

OPTIONS	DESCRIPTIONS	BENEFITS	AVAILABLE FOR MODELS
3390 ANTICONDENSATE HEATER EL.BOARD			
3391 ELECTRIC HEATER ON EL. BOARD	Electrical heater fed directly from the unit, is automatically activated at temperatures internal QE below 30 ° C (off state at higher than 40 ° C).	It avoids the risk of humidity condensation on the electrical panel.	ALL
3420 LIGHTS ON ELECTRIC BOARD			
3421 LIGHTS ON ELECTRIC BOARD	Electrical board equipped with lights.	Facilitate electrical board maintenance interventions.	ALL
3450 ELECTR. COMP. AS IEC 61000-6			
3451 EMC COMP. FOR RESIDENTIAL APP.	EMC compatibility for residential applications as per EN61000-6-3	Assure units' EMC compatibility as per EN61000-6-3, for residential, commercial and light industrial applications.	ALL
5920 MANAGEMENT & CONTROL SYSTEMS			
5921 NETWORK ANALYZER FOR DEMETRA	This option includes all following devices on-board the unit panel: - network analyzer operating on ModBUS protocol over RS-485 (without certification MID) - current transformers.	This accessory allows to acquire the electrical data and the power absorbed by the unit and send them via RS-485 bus to an external device for energy metering (DEMETRA - see dedicated manual).	ALL
5922 ClimaPRO ModBUS RS485 - MID	This option includes all following devices on-board the unit panel: - MID certified network analyzer operating on ModBUS over RS-485 - Current transformers - W3000TE controller - Software release LA09 or later version.	This accessory allows to acquire the electrical data and the power absorbed by the unit and communicate with ClimaPRO via high level communication interface based on ModBUS over EIA RS-485. More specifically, the data collected are: power supply, current, frequency, power factor ($\cos\phi$), electrical power consumption, energy consumption. This specific energy meter model is MID certified and can therefore be used for billing applications. This option also ensures the compatibility between the units and ClimaPRO, thus allowing ClimaPRO to acquire all the main unit's operating variables and status by means of a high level communication interface to the controller installed onboard the unit panel.	ALL
5923 ClimaPRO BacNET over IP	This option includes all following devices on-board the unit panel: - network analyzer operating on BACnet over IP - Current transformers - W3000TE controller - Software release LA09 or later version.	This accessory allows to acquire the electrical data and the power absorbed by the unit and communicate with ClimaPRO via high level communication interface based on BACnet over IP. More specifically, the data collected are: power supply, current, frequency, power factor ($\cos\phi$), electrical power consumption, energy consumption. This network analyzer is not MID certified and cannot therefore be used for billing applications. This option also ensures the compatibility between the units and ClimaPRO, thus allowing ClimaPRO to acquire all the main unit's operating variables and status by means of a high level communication interface to the controller installed onboard the unit panel.	ALL

OPTIONS

OPTIONS	DESCRIPTIONS	BENEFITS	AVAILABLE FOR MODELS
890 CONDENSING COIL			
881 Cu/Cu EXTERNAL COIL	Finned coil heat exchanger made from suitably-spaced copper tubes and fins designed to ensure maximum heat exchange efficiency.	This type of coil is not subject to galvanic corrosion, being made from just one material. For further information please refer to the Guidelines "Finned coil heat exchangers and protection against corrosion", available in the download section of the website www.climaveneta.com , or contact our sales department.	ALL
894 Cu PIPES/PREPAINTED ALL. FINS	Finned coil heat exchanger made from copper tubes and aluminum fins with chemical cleaning treatment to remove impurities, and then coated with protective paint with the following characteristics: - fins treated with protective polyester resin paint; - over 1000 hours of salt spray protection as per ASTM B117 (fins without cross and protected edges); - excellent resistance to UV rays.	Provide a good resistance against corrosion. For further information please refer to the Guidelines "Finned coil heat exchangers and protection against corrosion", available in the download section of the website www.climaveneta.com , or contact our sales department.	ALL
895 FIN GUARD SILVER TREATM	Copper-aluminum heat exchanger coils with polyurethane paint Fin Guard Silver SB. Coil completely coated by a protective layer of polyurethane paint with the following characteristics: - polyurethane paint with metallic emulsion; - over 3000 hours of salt spray protection as per ASTM B117; - excellent resistance to UV rays; - high-pressure spray painting system.	Provide a very high resistance against corrosion, also in very aggressive environment. For further information please refer to the Guidelines "Finned coil heat exchangers and protection against corrosion", available in the download section of the website www.climaveneta.com , or contact our sales department.	ALL
2000 COIL PROTECTION			
2001 COIL PROT.GRILLS IN PERALUMAN	Coil protecting grilles	Protects against the intrusion of solid bodies with mediumlarge dimensions.	ALL
820 FAN CONTROL			
808 EC FANS	Electronically commutated fans (EC fans). The brushless motor, governed by a special controller, continuously adjust fans' speed.	Reduced energy consumption and minimized current's absorption during start-up phase. The efficiency is increased by approximately: +1% of EER and +4/5% of ESEER. The noise reduces proportionally to the unit's partialization.	ALL
1800 EVAPORATOR WATER FLOW SWITCH			
1801 EVAPORATOR WATER FLOW SWITCH	Flow switch with stainless scoop AISI 316L and IP65 protection suitable for installation in industrial plant pipes. It should be installed in a straight pipe without filters, valves, etc., long at least 5 times its diameter, both upstream and downstream.	Signaling of lack of or excessive reduction of flow, it generates an alarm that is in automatic or manual reset depending on n ° alarms per hour and the maximum time of operation of the pump under conditions of low flow rate.	ALL
1802 EVAP.DIFFERENTIAL PRESS.SWITCH	Differential pressure switch in silicone membrane, compatible for water and glycolated solutions, suitable to the horizontal and vertical mounting, with an operating range between -20 ° C and + 85 ° C.		ALL
3180 PUMP ASSEMBLY			
3183 N.2 PUMPS WITH 4 POLES L.P.	Hydronic group (see dedicated section).		ALL
3184 N.2 PUMPS WITH 4 POLES H.P.	Hydronic group (see dedicated section).		ALL

OPTIONS

OPTIONS	DESCRIPTIONS	BENEFITS	AVAILABLE FOR MODELS
3240 PUMP ASSEMBLY WITH VPF SYSTEM			
3245 N.2 PUMPS 4 POL L.P+VPF	Inverter driven pumps with control for the plant's primary circuit (see dedicated section). This option includes: differential pressure transducer on the evaporator, additional control devices to read the signals (4-20 mA) coming from the differential pressure transducers on the evaporator and on the plant and to manage the pumps and the by-pass valve (0-10V signals). [Plant differential pressure transducers and by-pass valve to be supplied by others].		ALL
3246 N.2 PUMPS 4 POL H.P+VPF	Inverter driven pumps with control for the plant's primary circuit (see dedicated section). This option includes: differential pressure transducer on the evaporator, additional control devices to read the signals (4-20 mA) coming from the differential pressure transducers on the evaporator and on the plant and to manage the pumps and the by-pass valve (0-10V signals). [Plant differential pressure transducers and by-pass valve to be supplied by others].		ALL
2020 ANTI-INTRUSION GRILLS			
2021 ANTI-INTRUSION GRILLS	Anti-intrusions grills	Avoid the intrusion of solid bodies into the unit's structure.	ALL
9970 PACKING			
9965 NYLON + COIL PROT. PACKING	Unit provided plastic supports, with polypropylene panels for coils protection and covered with nylon		ALL
9967 COIL PROTECTION PACKING	Unit provided plastic supports and covered with nylon		ALL
9979 CONTAINER PACKING	Unit provided with container slides and covered with nylon		ALL

OPTIONS

5.2 Chiller Plant Control with Active Optimization System

ClimaPRO System Manager

ClimaPRO System Manager represents the state-of-the-art platform for chiller plant management and control. ClimaPRO ensures to actively optimize the entire chiller plant by managing and adjusting each component directly involved in the production and the distribution of the heating and the cooling energies, therefore involving chillers and heat pumps, pumping groups as well as the source-side devices like, for example, the cooling towers.

In particular, ClimaPRO measures in real-time all the operating variables from the field, for each individual device and each of the main system branches, by using serial communication lines as well as dedicated analogue signals.

The acquired data are then compared with the design data of each single unit at any different working conditions, thus allowing to implement control strategies based on dynamic algorithms which take into account the real operating conditions.

On the basis of these values, an advanced diagnostic module also allows to assess the level of efficiency for each individual unit, translating data into easy-to-read information in order to simplify and optimize the maintenance activities.

The "Chart Builder" software module allows to display the trends of the main operating variables. The "Reporting" module allows to send reports to selected users, including data and system's status of the main devices as well as to perform calculation of the energy indexes for each single unit and for the entire chiller plant.

The accessibility to ClimaPRO System Manager is ensured by an integrated web server that makes it visible from any computer equipped with a web browser, either locally or remotely.



6.1 GENERAL TECHNICAL DATA

TRCS2-G05-Z/SL-CA

[SI System]

TRCS2-G05-Z/SL-CA		0211	0251	0351	0452	0512	0552	0652	0712	0853	0913	
Power supply		V/ph/Hz 400/3/50 400/3/50 400/3/50 400/3/50 400/3/50 400/3/50 400/3/50 400/3/50 400/3/50 400/3/50 400/3/50										
PERFORMANCE												
COOLING ONLY (GROSS VALUE)												
Cooling capacity	(1)	kW	230,4	255,9	343,3	437,9	502,5	567,3	643,1	733,3	840,5	891,7
Total power input	(1)	kW	70,85	80,82	110,0	137,7	160,7	173,5	207,2	225,0	269,6	287,3
EER	(1)	kW/kW	3,254	3,167	3,121	3,180	3,127	3,270	3,104	3,259	3,118	3,104
ESEER	(1)	kW/kW										
COOLING ONLY (EN14511 VALUE)												
Cooling capacity	(1)(2)	kW	229,6	255,2	342,4	436,9	501,3	565,7	641,9	731,7	838,5	889,3
EER	(1)(2)	kW/kW	3,210	3,130	3,090	3,150	3,100	3,230	3,080	3,230	3,090	3,070
ESEER	(1)(2)	kW/kW	4,600	4,760	4,550	4,880	4,920	4,810	4,840	4,920	4,870	4,820
Cooling energy class			A	A	A	A	A	A	A	A	A	A
COOLING WITH PARTIAL RECOVERY												
Cooling capacity	(3)	kW	239,0	265,5	356,2	454,3	521,3	588,6	667,3	760,8	872,0	925,2
Total power input	(3)	kW	68,62	78,25	106,5	133,3	155,5	167,9	200,5	217,7	260,9	278,0
Desuperheater heating capacity	(3)	kW	56,82	65,72	89,61	112,2	132,7	142,0	169,9	185,9	221,4	235,0
EXCHANGERS												
HEAT EXCHANGER USER SIDE IN REFRIGERATION												
Water flow	(1)	l/s	11,02	12,24	16,42	20,94	24,03	27,13	30,76	35,07	40,19	42,64
Pressure drop	(1)	kPa	35,7	27,0	28,1	27,0	27,0	34,4	20,7	26,9	31,2	35,1
PARTIAL RECOVERY USER SIDE IN REFRIGERATION												
Water flow	(3)	l/s	2,743	3,172	4,325	5,418	6,406	6,855	8,203	8,972	10,69	11,34
Pressure drop	(3)	kPa	43,5	58,2	52,6	26,7	37,4	42,8	47,0	56,2	42,3	49,5
REFRIGERANT CIRCUIT												
Compressors nr.		N°	1	1	1	2	2	2	2	2	3	3
Number of capacity steps		N°	0	0	0	0	0	0	0	0	0	0
No. Circuits		N°	1	1	1	1	1	1	1	1	2	2
Regulation			STEPLESS STEPLESS STEPLESS STEPLESS STEPLESS STEPLESS STEPLESS STEPLESS STEPLESS STEPLESS									
Min. capacity step		%	-	-	-	-	-	-	-	-	-	-
Refrigerant			R513A	R513A	R513A	R513A	R513A	R513A	R513A	R513A	R513A	R513A
Refrigerant charge		kg	100	100	120	210	180	210	240	280	340	430
Oil charge		kg	0,00	0,00	0,00	0,00	0,00	0,00	0,00	0,00	0,00	0,00
Rc (ASHRAE)	(4)	kg/kW	0,44	0,40	0,35	0,48	0,36	0,37	0,38	0,39	0,41	0,49
FANS												
Quantity		N°	6	6	8	10	10	12	14	14	10	14
Air flow		m³/s	23,54	23,54	31,86	40,12	38,06	48,49	57,80	54,93	65,35	81,40
Fans power input		kW	1,20	1,20	1,20	1,20	1,20	1,20	1,20	1,20	1,20	1,20
NOISE LEVEL												
Sound Pressure	(5)	dB(A)	56	56	58	58	58	59	59	59	60	60
Sound power level in cooling	(6)(7)	dB(A)	88	88	90	90	90	91	92	92	93	93
SIZE AND WEIGHT												
A	(8)	mm	3100	3100	4000	4900	4900	5800	7000	7000	8500	9700
B	(8)	mm	2260	2260	2260	2260	2260	2260	2260	2260	2260	2260
H	(8)	mm	2430	2430	2430	2430	2430	2430	2430	2430	2430	2430
Operating weight	(8)	kg	2320	2370	3050	4000	4240	4530	5800	6150	6940	7370

Notes:

- 1 Plant (side) cooling exchanger water (in/out) 12,00°C/7,00°C; Source (side) heat exchanger air (in) 35,0°C.
- 2 Values in compliance with EN14511
- 3 Plant (side) cooling exchanger water (in/out) 12,00°C/7,00°C; Source (side) heat exchanger air (in) 35,0°C; Plant (side) heat exchanger recovery water (in/out) 40,00°C/45,00°C.
- 4 Rated in accordance with AHRI Standard 550/590 (2011 with addendum 1).
- 5 Average sound pressure level at 10m distance, unit in a free field on a reflective surface; non-binding value calculated from the sound power level.
- 6 Sound power on the basis of measurements made in compliance with ISO 9614.
- 7 Sound power level in cooling, outdoors.
- 8 Unit in standard configuration/execution, without optional accessories.

- Not available

Certified data in EUROVENT

GENERAL TECHNICAL DATA

TRCS2-G05-Z/SL-CA

[SI System]

TRCS2-G05-Z/SL-CA		1013	1054	1154
Power supply		V/ph/Hz 400/3/50	400/3/50	400/3/50
PERFORMANCE				
COOLING ONLY (GROSS VALUE)				
Cooling capacity	(1)	kW 964,6	1056	1173
Total power input	(1)	kW 309,1	335,2	373,3
EER	(1)	kW/kW 3,121	3,150	3,142
ESEER	(1)	kW/kW		
COOLING ONLY (EN14511 VALUE)				
Cooling capacity	(1)(2)	kW 962,5	1053	1170
EER	(1)(2)	kW/kW 3,090	3,120	3,110
ESEER	(1)(2)	kW/kW 4,850	4,830	4,890
Cooling energy class		A	A	A
COOLING WITH PARTIAL RECOVERY				
Cooling capacity	(3)	kW 1001	1096	1217
Total power input	(3)	kW 299,2	324,4	361,3
Desuperheater heating capacity	(3)	kW 252,3	273,5	307,5
EXCHANGERS				
HEAT EXCHANGER USER SIDE IN REFRIGERATION				
Water flow	(1)	l/s 46,13	50,52	56,08
Pressure drop	(1)	kPa 29,0	34,7	36,7
PARTIAL RECOVERY USER SIDE IN REFRIGERATION				
Water flow	(3)	l/s 12,18	13,20	14,84
Pressure drop	(3)	kPa 46,1	39,7	38,6
REFRIGERANT CIRCUIT				
Compressors nr.		N° 3	4	4
Number of capacity steps		N° 0	0	0
No. Circuits		N° 2	2	2
Regulation		STEPLESS STEPLESS STEPLESS		
Min. capacity step		% -	-	-
Refrigerant		R513A R513A R513A		
Refrigerant charge		kg 490	480	520
Oil charge		kg 0,00	0,00	0,00
Rc (ASHRAE)	(4)	kg/kW 0,51	0,46	0,45
FANS				
Quantity		N° 14	24	24
Air flow		m³/s 89,54	96,98	101,20
Fans power input		kW 1,20	1,20	1,20
NOISE LEVEL				
Sound Pressure	(5)	dB(A) 60	61	61
Sound power level in cooling	(6)(7)	dB(A) 93	94	94
SIZE AND WEIGHT				
A	(8)	mm 10600	11200	11500
B	(8)	mm 2260	2260	2260
H	(8)	mm 2430	2430	2430
Operating weight	(8)	kg 8150	8700	9020

Notes:

- 1 Plant (side) cooling exchanger water (in/out) 12,00°C/7,00°C; Source (side) heat exchanger air (in) 35,0°C.
- 2 Values in compliance with EN14511
- 3 Plant (side) cooling exchanger water (in/out) 12,00°C/7,00°C; Source (side) heat exchanger air (in) 35,0°C; Plant (side) heat exchanger recovery water (in/out) 40,00°C/45,00°C.
- 4 Rated in accordance with AHRI Standard 550/590 (2011 with addendum 1).
- 5 Average sound pressure level at 10m distance, unit in a free field on a reflective surface; non-binding value calculated from the sound power level.
- 6 Sound power on the basis of measurements made in compliance with ISO 9614.
- 7 Sound power level in cooling, outdoors.
- 8 Unit in standard configuration/execution, without optional accessories.

- Not available

Certified data in EUROVENT

GENERAL TECHNICAL DATA

TRCS2-G05-Z/XL-CA

[SI System]

TRCS2-G05-Z/XL-CA		0211	0251	0351	0452	0512	0552	0652	0712	0853	0913	
Power supply		V/ph/Hz 400/3/50 400/3/50 400/3/50 400/3/50 400/3/50 400/3/50 400/3/50 400/3/50 400/3/50 400/3/50 400/3/50										
PERFORMANCE												
COOLING ONLY (GROSS VALUE)												
Cooling capacity	(1)	kW	217,9	252,4	338,6	431,0	519,2	573,0	634,0	730,0	865,8	888,0
Total power input	(1)	kW	68,84	79,54	109,0	135,9	165,3	171,1	205,8	226,0	279,0	290,4
EER	(1)	kW/kW	3,167	3,175	3,106	3,171	3,141	3,349	3,081	3,230	3,103	3,058
ESEER	(1)	kW/kW										
COOLING ONLY (EN14511 VALUE)												
Cooling capacity	(1)(2)	kW	217,2	251,7	337,7	430,0	517,9	571,4	632,9	728,4	863,6	885,7
EER	(1)(2)	kW/kW	3,120	3,140	3,070	3,140	3,110	3,310	3,060	3,200	3,070	3,030
ESEER	(1)(2)	kW/kW	4,610	4,860	4,670	4,990	4,980	4,900	4,990	4,990	4,980	4,990
Cooling energy class			A	A	B	A	A	A	B	A	A	B
COOLING WITH PARTIAL RECOVERY												
Cooling capacity	(3)	kW	226,1	261,9	351,3	447,1	538,6	594,5	657,8	757,4	898,3	921,3
Total power input	(3)	kW	66,62	76,94	105,5	131,5	159,9	165,5	199,0	218,6	269,8	280,8
Desuperheater heating capacity	(3)	kW	56,63	66,18	90,89	113,3	137,9	141,5	172,4	188,8	232,9	243,1
EXCHANGERS												
HEAT EXCHANGER USER SIDE IN REFRIGERATION												
Water flow	(1)	l/s	10,42	12,07	16,19	20,61	24,83	27,40	30,32	34,91	41,40	42,47
Pressure drop	(1)	kPa	32,0	26,3	27,3	26,2	28,8	35,1	20,1	26,7	33,1	34,8
PARTIAL RECOVERY USER SIDE IN REFRIGERATION												
Water flow	(3)	l/s	2,733	3,194	4,387	5,468	6,658	6,828	8,324	9,116	11,24	11,74
Pressure drop	(3)	kPa	43,2	59,0	54,1	27,2	40,4	42,5	48,4	58,0	46,9	53,0
REFRIGERANT CIRCUIT												
Compressors nr.		N°	1	1	1	2	2	2	2	2	3	3
Number of capacity steps		N°	0	0	0	0	0	0	0	0	0	0
No. Circuits		N°	1	1	1	1	1	1	1	1	2	2
Regulation			STEPLESS STEPLESS STEPLESS STEPLESS STEPLESS STEPLESS STEPLESS STEPLESS STEPLESS STEPLESS									
Min. capacity step		%	-	-	-	-	-	-	-	-	-	-
Refrigerant			R513A	R513A	R513A	R513A	R513A	R513A	R513A	R513A	R513A	R513A
Refrigerant charge		kg	100	100	130	220	220	240	270	310	410	450
Oil charge		kg	0,00	0,00	0,00	0,00	0,00	0,00	0,00	0,00	0,00	0,00
Rc (ASHRAE)	(4)	kg/kW	0,46	0,40	0,39	0,52	0,43	0,42	0,43	0,43	0,48	0,51
FANS												
Quantity		N°	6	6	8	10	12	14	14	16	12	14
Air flow		m³/s	18,93	17,98	24,18	30,49	36,91	46,40	44,18	50,49	60,99	62,05
Fans power input		kW	0,90	0,90	0,90	0,90	0,90	0,90	0,90	0,90	0,90	0,90
NOISE LEVEL												
Sound Pressure	(5)	dB(A)	50	50	51	51	52	52	52	53	53	53
Sound power level in cooling	(6)(7)	dB(A)	82	82	83	83	84	85	85	86	86	86
SIZE AND WEIGHT												
A	(8)	mm	3100	3100	4000	4900	5800	7000	7000	7900	9400	9700
B	(8)	mm	2260	2260	2260	2260	2260	2260	2260	2260	2260	2260
H	(8)	mm	2430	2430	2430	2430	2430	2430	2430	2430	2430	2430
Operating weight	(8)	kg	2370	2420	3200	4240	4690	5350	6150	6650	7520	7770

Notes:

- 1 Plant (side) cooling exchanger water (in/out) 12,00°C/7,00°C; Source (side) heat exchanger air (in) 35,0°C.
- 2 Values in compliance with EN14511
- 3 Plant (side) cooling exchanger water (in/out) 12,00°C/7,00°C; Source (side) heat exchanger air (in) 35,0°C; Plant (side) heat exchanger recovery water (in/out) 40,00°C/45,00°C.
- 4 Rated in accordance with AHRI Standard 550/590 (2011 with addendum 1).
- 5 Average sound pressure level at 10m distance, unit in a free field on a reflective surface; non-binding value calculated from the sound power level.
- 6 Sound power on the basis of measurements made in compliance with ISO 9614.
- 7 Sound power level in cooling, outdoors.
- 8 Unit in standard configuration/execution, without optional accessories.

- Not available

Certified data in EUROVENT



GENERAL TECHNICAL DATA

TRCS2-G05-Z/XL-CA

[SI System]

TRCS2-G05-Z/XL-CA		1013	1054	1154
Power supply		V/ph/Hz 400/3/50	400/3/50	400/3/50
PERFORMANCE				
COOLING ONLY (GROSS VALUE)				
Cooling capacity	(1)	kW 959,1	1040	1163
Total power input	(1)	kW 311,0	330,3	376,9
EER	(1)	kW/kW 3,084	3,149	3,086
ESEER	(1)	kW/kW		
COOLING ONLY (EN14511 VALUE)				
Cooling capacity	(1)(2)	kW 957,0	1037	1160
EER	(1)(2)	kW/kW 3,060	3,120	3,050
ESEER	(1)(2)	kW/kW 4,990	4,950	4,970
Cooling energy class		B	A	B
COOLING WITH PARTIAL RECOVERY				
Cooling capacity	(3)	kW 995,1	1079	1207
Total power input	(3)	kW 300,8	319,5	364,6
Desuperheater heating capacity	(3)	kW 259,9	275,5	315,6
EXCHANGERS				
HEAT EXCHANGER USER SIDE IN REFRIGERATION				
Water flow	(1)	l/s 45,87	49,75	55,63
Pressure drop	(1)	kPa 28,6	33,7	36,1
PARTIAL RECOVERY USER SIDE IN REFRIGERATION				
Water flow	(3)	l/s 12,55	13,30	15,23
Pressure drop	(3)	kPa 49,0	40,3	40,6
REFRIGERANT CIRCUIT				
Compressors nr.		N° 3	4	4
Number of capacity steps		N° 0	0	0
No. Circuits		N° 2	2	2
Regulation		STEPLESS STEPLESS STEPLESS		
Min. capacity step		% -	-	-
Refrigerant		R513A R513A R513A		
Refrigerant charge		kg 520	500	580
Oil charge		kg 0,00	0,00	0,00
Rc (ASHRAE)	(4)	kg/kW 0,55	0,49	0,50
FANS				
Quantity		N° 14	24	26
Air flow		m³/s 68,25	73,82	80,66
Fans power input		kW 0,90	0,90	0,90
NOISE LEVEL				
Sound Pressure	(5)	dB(A) 54	54	55
Sound power level in cooling	(6)(7)	dB(A) 87	87	88
SIZE AND WEIGHT				
A	(8)	mm 10600	11200	12400
B	(8)	mm 2260	2260	2260
H	(8)	mm 2430	2430	2430
Operating weight	(8)	kg 8650	9150	9960

Notes:

- 1 Plant (side) cooling exchanger water (in/out) 12,00°C/7,00°C; Source (side) heat exchanger air (in) 35,0°C.
- 2 Values in compliance with EN14511
- 3 Plant (side) cooling exchanger water (in/out) 12,00°C/7,00°C; Source (side) heat exchanger air (in) 35,0°C; Plant (side) heat exchanger recovery water (in/out) 40,00°C/45,00°C.
- 4 Rated in accordance with AHRI Standard 550/590 (2011 with addendum 1).
- 5 Average sound pressure level at 10m distance, unit in a free field on a reflective surface; non-binding value calculated from the sound power level.
- 6 Sound power on the basis of measurements made in compliance with ISO 9614.
- 7 Sound power level in cooling, outdoors.
- 8 Unit in standard configuration/execution, without optional accessories.

- Not available

Certified data in EUROVENT



GENERAL TECHNICAL DATA

TRCS2-G05-Z/SL-CA-E

[SI System]

TRCS2-G05-Z/SL-CA-E		0211	0251	0351	0452	0512	0552	0652	0712	0853	0913
Power supply		V/ph/Hz 400/3/50 400/3/50 400/3/50 400/3/50 400/3/50 400/3/50 400/3/50 400/3/50 400/3/50 400/3/50 400/3/50									
PERFORMANCE											
COOLING ONLY (GROSS VALUE)											
Cooling capacity	(1)	kW 226,4	282,8	381,9	450,5	520,5	583,5	695,8	786,2	894,0	956,7
Total power input	(1)	kW 67,41	81,04	112,7	133,0	154,1	168,3	203,5	233,3	263,0	279,5
EER	(1)	kW/kW 3,359	3,491	3,389	3,387	3,378	3,467	3,419	3,370	3,399	3,423
ESEER	(1)	kW/kW									
COOLING ONLY (EN14511 VALUE)											
Cooling capacity	(1)(2)	kW 225,6	281,9	380,8	449,4	519,2	581,8	694,4	784,3	891,6	953,9
EER	(1)(2)	kW/kW 3,310	3,440	3,340	3,350	3,340	3,420	3,390	3,330	3,360	3,380
ESEER	(1)(2)	kW/kW 5,100	5,300	5,200	5,520	5,400	5,300	5,530	5,460	5,310	5,400
Cooling energy class		A	A	A	A	A	A	A	A	A	A
COOLING WITH PARTIAL RECOVERY											
Cooling capacity	(3)	kW 234,9	293,4	396,2	467,4	540,0	605,4	721,8	815,7	927,5	992,6
Total power input	(3)	kW 65,23	78,38	109,0	128,7	149,0	162,8	196,8	225,6	254,3	270,3
Desuperheater heating capacity	(3)	kW 55,62	67,78	94,53	111,1	129,9	141,2	171,0	196,1	221,1	234,3
EXCHANGERS											
HEAT EXCHANGER USER SIDE IN REFRIGERATION											
Water flow	(1)	l/s 10,83	13,52	18,26	21,55	24,89	27,90	33,27	37,60	42,75	45,75
Pressure drop	(1)	kPa 34,5	33,0	34,7	28,6	29,0	36,4	24,2	31,0	35,3	40,4
PARTIAL RECOVERY USER SIDE IN REFRIGERATION											
Water flow	(3)	l/s 2,685	3,272	4,563	5,365	6,271	6,814	8,254	9,465	10,67	11,31
Pressure drop	(3)	kPa 41,7	61,9	58,6	26,2	35,8	42,3	47,6	62,6	42,2	49,2
REFRIGERANT CIRCUIT											
Compressors nr.		N° 1	1	1	2	2	2	2	2	3	3
Number of capacity steps		N° 0	0	0	0	0	0	0	0	0	0
No. Circuits		N° 1	1	1	1	1	1	1	1	2	2
Regulation		STEPLESS STEPLESS STEPLESS STEPLESS STEPLESS STEPLESS STEPLESS STEPLESS STEPLESS STEPLESS									
Min. capacity step		% -	-	-	-	-	-	-	-	-	-
Refrigerant		R513A R513A R513A R513A R513A R513A R513A R513A R513A R513A R513A									
Refrigerant charge		kg 100	100	130	220	220	240	270	310	410	450
Oil charge		kg 0,00	0,00	0,00	0,00	0,00	0,00	0,00	0,00	0,00	0,00
Rc (ASHRAE)	(4)	kg/kW 0,45	0,36	0,34	0,49	0,43	0,42	0,39	0,40	0,46	0,48
FANS											
Quantity		N° 6	6	8	10	10	12	14	16	10	14
Air flow		m³/s 23,54	22,31	30,22	38,06	38,06	46,03	54,93	62,78	68,52	77,30
Fans power input		kW 0,85	0,85	0,85	0,85	0,85	0,85	0,85	0,85	0,85	0,85
NOISE LEVEL											
Sound Pressure	(5)	dB(A) 56	56	58	58	58	59	59	59	60	60
Sound power level in cooling	(6)(7)	dB(A) 88	88	90	90	90	91	92	92	93	93
SIZE AND WEIGHT											
A	(8)	mm 3100	3100	4000	4900	4900	5800	7000	7900	8500	9700
B	(8)	mm 2260	2260	2260	2260	2260	2260	2260	2260	2260	2260
H	(8)	mm 2430	2430	2430	2430	2430	2430	2430	2430	2430	2430
Operating weight	(8)	kg 2270	2350	3130	4070	4230	4570	6040	6450	7020	7610

Notes:

- 1 Plant (side) cooling exchanger water (in/out) 12,00°C/7,00°C; Source (side) heat exchanger air (in) 35,0°C.
- 2 Values in compliance with EN14511
- 3 Plant (side) cooling exchanger water (in/out) 12,00°C/7,00°C; Source (side) heat exchanger air (in) 35,0°C; Plant (side) heat exchanger recovery water (in/out) 40,00°C/45,00°C.
- 4 Rated in accordance with AHRI Standard 550/590 (2011 with addendum 1).
- 5 Average sound pressure level at 10m distance, unit in a free field on a reflective surface; non-binding value calculated from the sound power level.
- 6 Sound power on the basis of measurements made in compliance with ISO 9614.
- 7 Sound power level in cooling, outdoors.
- 8 Unit in standard configuration/execution, without optional accessories.

- Not available

Certified data in EUROVENT



GENERAL TECHNICAL DATA

TRCS2-G05-Z/SL-CA-E

[SI System]

TRCS2-G05-Z/SL-CA-E		1013	1054	1154
Power supply		V/ph/Hz 400/3/50	400/3/50	400/3/50
PERFORMANCE				
COOLING ONLY (GROSS VALUE)				
Cooling capacity	(1)	kW 1071	1168	1313
Total power input	(1)	kW 316,2	335,5	382,5
EER	(1)	kW/kW 3,387	3,481	3,433
ESEER	(1)	kW/kW		
COOLING ONLY (EN14511 VALUE)				
Cooling capacity	(1)(2)	kW 1068	1164	1309
EER	(1)(2)	kW/kW 3,350	3,430	3,380
ESEER	(1)(2)	kW/kW 5,390	5,530	5,380
Cooling energy class		A	A	A
COOLING WITH PARTIAL RECOVERY				
Cooling capacity	(3)	kW 1112	1212	1362
Total power input	(3)	kW 305,7	324,5	369,9
Desuperheater heating capacity	(3)	kW 265,5	281,3	321,7
EXCHANGERS				
HEAT EXCHANGER USER SIDE IN REFRIGERATION				
Water flow	(1)	l/s 51,24	55,85	62,77
Pressure drop	(1)	kPa 35,7	42,4	46,0
PARTIAL RECOVERY USER SIDE IN REFRIGERATION				
Water flow	(3)	l/s 12,82	13,58	15,53
Pressure drop	(3)	kPa 51,1	42,1	42,2
REFRIGERANT CIRCUIT				
Compressors nr.		N° 3	4	4
Number of capacity steps		N° 0	0	0
No. Circuits		N° 2	2	2
Regulation		STEPLESS	STEPLESS	STEPLESS
Min. capacity step		% -	-	-
Refrigerant		R513A	R513A	R513A
Refrigerant charge		kg 520	500	580
Oil charge		kg 0,00	0,00	0,00
Rc (ASHRAE)	(4)	kg/kW 0,49	0,43	0,45
FANS				
Quantity		N° 14	24	26
Air flow		m³/s 85,03	92,06	101,25
Fans power input		kW 0,85	0,85	0,85
NOISE LEVEL				
Sound Pressure	(5)	dB(A) 60	61	62
Sound power level in cooling	(6)(7)	dB(A) 93	94	95
SIZE AND WEIGHT				
A	(8)	mm 10600	11200	12400
B	(8)	mm 2260	2260	2260
H	(8)	mm 2430	2430	2430
Operating weight	(8)	kg 8510	8660	9720

Notes:

- 1 Plant (side) cooling exchanger water (in/out) 12,00°C/7,00°C; Source (side) heat exchanger air (in) 35,0°C.
- 2 Values in compliance with EN14511
- 3 Plant (side) cooling exchanger water (in/out) 12,00°C/7,00°C; Source (side) heat exchanger air (in) 35,0°C; Plant (side) heat exchanger recovery water (in/out) 40,00°C/45,00°C.
- 4 Rated in accordance with AHRI Standard 550/590 (2011 with addendum 1).
- 5 Average sound pressure level at 10m distance, unit in a free field on a reflective surface; non-binding value calculated from the sound power level.
- 6 Sound power on the basis of measurements made in compliance with ISO 9614.
- 7 Sound power level in cooling, outdoors.
- 8 Unit in standard configuration/execution, without optional accessories.

- Not available

Certified data in EUROVENT

7.1 TECHNICAL DATA SEASONAL EFFICIENCY IN COOLING (EN14825 VALUE)

[SI System]

ENERGY EFFICIENCY

SEASONAL EFFICIENCY IN COOLING (Reg. EU 2016/2281)

Process refrigeration at high temperature

TRCS2-G05-Z/SL-CA			0211	0251	0351	0452	0512	0552	0652	0712	0853	0913
Prated,c	(1)	kW	229,59	255,18	342,39	436,86	501,30	565,70	641,90	731,70	838,46	889,30
SEPR	(1) (3)	-	5,80	5,87	6,04	5,92	6,00	5,68	6,15	6,06	5,98	5,98
TRCS2-G05-Z/SL-CA			1013	1054	1154							
Prated,c	(1)	kW	962,45	1053,00	1169,89							
SEPR	(1) (3)	-	6,09	5,89	6,09							

TRCS2-G05-Z/XL-CA			0211	0251	0351	0452	0512	0552	0652	0712	0853	0913
Prated,c	(1)	kW	217,17	251,70	337,70	430,00	517,90	571,37	632,89	728,40	863,60	885,66
SEPR	(1) (3)	-	5,93	6,13	6,28	6,14	6,10	5,92	6,38	6,18	6,13	6,18
TRCS2-G05-Z/XL-CA			1013	1054	1154							
Prated,c	(1)	kW	956,98	1037,00	1159,95							
SEPR	(1) (3)	-	6,30	6,13	6,28							

TRCS2-G05-Z/SL-CA-E			0211	0251	0351	0452	0512	0552	0652	0712	0853	0913
Prated,c	(1)	kW	225,60	281,90	380,75	449,38	519,20	581,80	694,40	784,29	891,60	953,86
SEPR	(1) (3)	-	6,32	6,24	6,45	6,56	6,29	6,23	6,68	6,44	6,36	6,51
TRCS2-G05-Z/SL-CA-E			1013	1054	1154							
Prated,c	(1)	kW	1068,00	1164,00	1308,84							
SEPR	(1) (3)	-	6,53	6,20	6,43							

SEASONAL EFFICIENCY IN COOLING (Reg. EU 2015/1095)

Process refrigeration at medium temperature

Notes:

(1) Seasonal energy efficiency of high temperature process cooling [REGULATION (EU) N. 2016/2281]

(2) Seasonal Energy Efficiency of Process Cooling at Medium Temperature [REGULATION (EU) N. 2015/1095]

(3) Seasonal energy efficiency ratio

The units highlighted in this publication contain R513A [GWP₁₀₀ 631] fluorinated greenhouse gases.

Certified data in EUROVENT

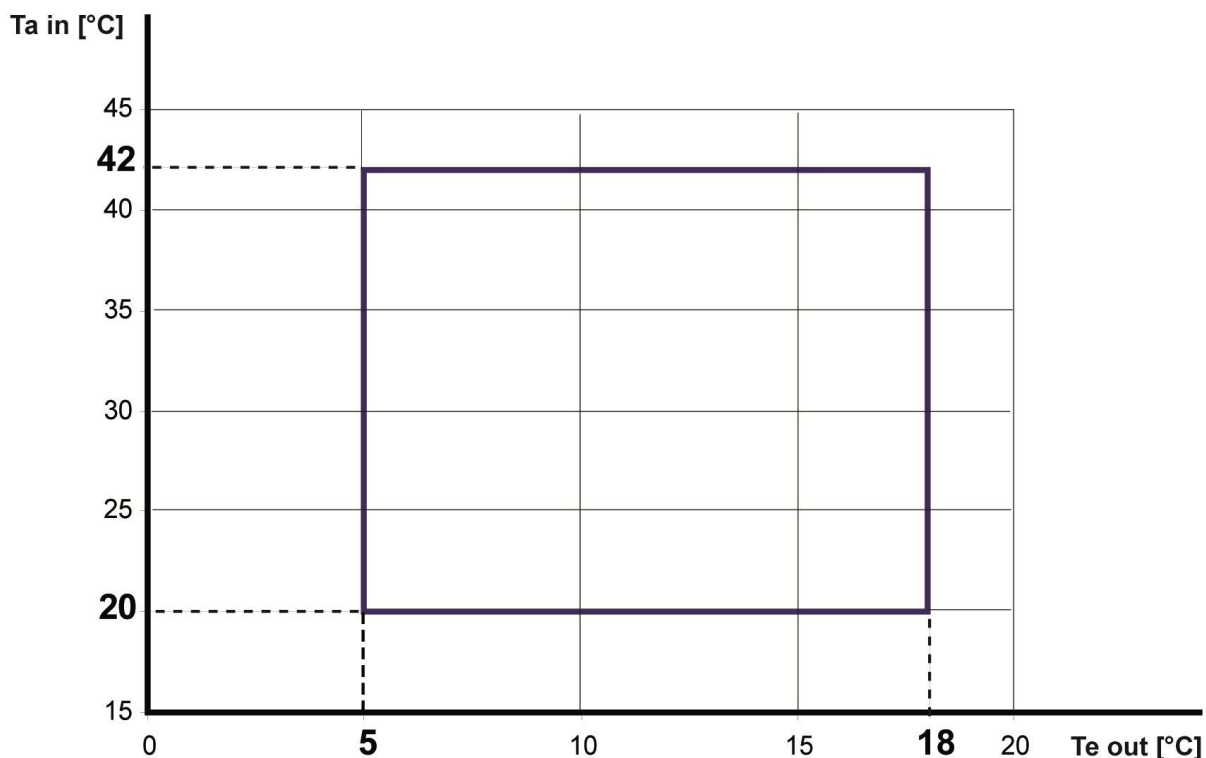

Ta in Outdoor air temperature [°C]
Te out Evaporator outlet temperature [°C]

The diagram shows the unit's operating range.
 Warning: approximately above 36°C outdoor temperature, the unit is supposed to work in not silenced mode.

NOTE:
 The represented operating limit refers to the standard unit's operation.
 Thanks to the condensation and evaporation control device adopted in TECS2 line, the units can work in each of the possible operating mode from -10°C up to 42°C outdoor air temperature.

SIZE				
TRCS2-G05-Z /SL-CA 0211	TRCS2-G05-Z /SL-CA 0913	TRCS2-G05-Z /D /SL-CA 0552	TRCS2-G05-Z /XL-CA 0251	TRCS2-G05-Z /XL-CA 1013
TRCS2-G05-Z /SL-CA 0251	TRCS2-G05-Z /SL-CA 1013	TRCS2-G05-Z /D /SL-CA 0652	TRCS2-G05-Z /XL-CA 0351	TRCS2-G05-Z /XL-CA 1054
TRCS2-G05-Z /SL-CA 0351	TRCS2-G05-Z /SL-CA 1054	TRCS2-G05-Z /D /SL-CA 0712	TRCS2-G05-Z /XL-CA 0452	TRCS2-G05-Z /XL-CA 1154
TRCS2-G05-Z /SL-CA 0452	TRCS2-G05-Z /SL-CA 1154	TRCS2-G05-Z /D /SL-CA 0853	TRCS2-G05-Z /XL-CA 0512	TRCS2-G05-Z /D /XL-CA 0211
TRCS2-G05-Z /SL-CA 0512	TRCS2-G05-Z /D /SL-CA 0211	TRCS2-G05-Z /D /SL-CA 0913	TRCS2-G05-Z /XL-CA 0552	TRCS2-G05-Z /D /XL-CA 0251
TRCS2-G05-Z /SL-CA 0552	TRCS2-G05-Z /D /SL-CA 0251	TRCS2-G05-Z /D /SL-CA 1013	TRCS2-G05-Z /XL-CA 0652	TRCS2-G05-Z /D /XL-CA 0351
TRCS2-G05-Z /SL-CA 0652	TRCS2-G05-Z /D /SL-CA 0351	TRCS2-G05-Z /D /SL-CA 1054	TRCS2-G05-Z /XL-CA 0712	TRCS2-G05-Z /D /XL-CA 0452
TRCS2-G05-Z /SL-CA 0712	TRCS2-G05-Z /D /SL-CA 0452	TRCS2-G05-Z /D /SL-CA 1154	TRCS2-G05-Z /XL-CA 0853	TRCS2-G05-Z /D /XL-CA 0512
TRCS2-G05-Z /SL-CA 0853	TRCS2-G05-Z /D /SL-CA 0512	TRCS2-G05-Z /XL-CA 0211	TRCS2-G05-Z /XL-CA 0913	TRCS2-G05-Z /D /XL-CA 0552

OPERATING LIMITS

TRCS2-G05-Z 0211 - 1154

SIZE
TRCS2-G05-Z /D /XL-CA 0652
TRCS2-G05-Z /D /XL-CA 0712
TRCS2-G05-Z /D /XL-CA 0853
TRCS2-G05-Z /D /XL-CA 0913
TRCS2-G05-Z /D /XL-CA 1013
TRCS2-G05-Z /D /XL-CA 1054
TRCS2-G05-Z /D /XL-CA 1154
TRCS2-G05-Z /SL-CA-E 0211
TRCS2-G05-Z /SL-CA-E 0251
TRCS2-G05-Z /SL-CA-E 0351
TRCS2-G05-Z /SL-CA-E 0452
TRCS2-G05-Z /SL-CA-E 0512
TRCS2-G05-Z /SL-CA-E 0552
TRCS2-G05-Z /SL-CA-E 0652
TRCS2-G05-Z /SL-CA-E 0712
TRCS2-G05-Z /SL-CA-E 0853
TRCS2-G05-Z /SL-CA-E 0913
TRCS2-G05-Z /SL-CA-E 1013
TRCS2-G05-Z /SL-CA-E 1054
TRCS2-G05-Z /SL-CA-E 1154
TRCS2-G05-Z /D /SL-CA-E 0211
TRCS2-G05-Z /D /SL-CA-E 0251
TRCS2-G05-Z /D /SL-CA-E 0351
TRCS2-G05-Z /D /SL-CA-E 0452
TRCS2-G05-Z /D /SL-CA-E 0512
TRCS2-G05-Z /D /SL-CA-E 0552
TRCS2-G05-Z /D /SL-CA-E 0652
TRCS2-G05-Z /D /SL-CA-E 0712
TRCS2-G05-Z /D /SL-CA-E 0853
TRCS2-G05-Z /D /SL-CA-E 0913
TRCS2-G05-Z /D /SL-CA-E 1013
TRCS2-G05-Z /D /SL-CA-E 1054
TRCS2-G05-Z /D /SL-CA-E 1154

8.2 ETHYLENE GLYCOL MIXTURE

Ethylene glycol and water mixture, used as a heat-conveying fluid, cause a variation in unit performance. For correct data, use the factors indicated in the following tabel.

	Freezing point (°C)							
	0	-5	-10	-15	-20	-25	-30	-35
	Ethylene glycol percentage by weight							
	0%	12%	20%	30%	35%	40%	45%	50%
cPf	1	0,985	0,98	0,974	0,97	0,965	0,964	0,96
cQ	1	1,02	1,04	1,075	1,11	1,14	1,17	1,2
cdp	1	1,07	1,11	1,18	1,22	1,24	1,27	1,3

cPf: cooling power correction factor
 cQ: flow correction factor
 cdp: pressure drop correction factor

For data concerning other kind of anti-freeze solutions (e.g, propylene glycol) please contact our Sale Department.

8.3 FOULING FACTORS

Performances are based on clean condition of tubes (fouling factor = 1). For different fouling values, performance should be adjusted using the correction factors shown in the following table.

SERIES	FOULING FACTORS	EVAPORATOR			CONDENSER/RECOVERY			DESUPERHEATER
	ff (m ² °CW)	F1	FK1	KE [°C]	F2	FK2	KC [°C]	R3
VARIOUS	0	1,000	1,000	0,0	1,000	1,000	0,0	1,000
VARIOUS	1,80 x 10 ⁻⁵	1,000	1,000	0,0	1,000	1,000	0,0	1,000
VARIOUS	4,40 x 10 ⁻⁵	1,000	1,000	0,0	0,990	1,030	1,0	0,990
VARIOUS	8,80 x 10 ⁻⁵	0,960	0,990	0,7	0,980	1,040	1,5	0,980
VARIOUS	13,20 x 10 ⁻⁵	0,944	0,985	1,0	0,964	1,050	2,3	0,964
VARIOUS	17,20 x 10 ⁻⁵	0,930	0,980	1,5	0,950	1,060	3,0	0,950

ff: fouling factors
 F1 - F2: potential correction factors
 FK1 - FK2: compressor power input correction factors
 R3: capacity correction factors
 KE: minimum evaporator outlet temperature increase
 KC: maximum condenser outlet temperature decrease

9.1 HYDRAULIC DATA

[SI System]

Water flow and pressure drop

Water flow in the plant (side) exchanger is given by:

$$Q = P / (4,186 \times Dt)$$

Q: water flow (l/s)

Dt: difference between inlet and outlet water temp. (°C)

P: heat exchanger capacity (kW)

Pressure drop is given by:

$$Dp = K \times (3,6 \times Q)^2 / 1000$$

Q: water flow (l/s)

Dp: pressure drop (kPa)

K: unit size ratio

SIZE	Power supply V/ph/Hz	HEAT EXCHANGER USER SIDE					HEAT RECOVERY EX. USER SIDE			
		K	Q min l/s	Q max l/s	C.A.S. l	C.a. min l	K	Q min l/s	Q max l/s	C.A.S. l
TRCS2-G05-Z /SL-CA 0211	400/3/50	22,7	6,389	17,22	-	5000	-	-	-	-
TRCS2-G05-Z /SL-CA 0251	400/3/50	13,9	8,056	22,22	-	5000	-	-	-	-
TRCS2-G05-Z /SL-CA 0351	400/3/50	8,04	10,00	27,78	-	5000	-	-	-	-
TRCS2-G05-Z /SL-CA 0452	400/3/50	4,76	13,89	38,33	-	5000	-	-	-	-
TRCS2-G05-Z /SL-CA 0512	400/3/50	3,61	16,11	44,44	-	5000	-	-	-	-
TRCS2-G05-Z /SL-CA 0552	400/3/50	3,61	16,11	44,44	-	5000	-	-	-	-
TRCS2-G05-Z /SL-CA 0652	400/3/50	1,69	21,11	58,06	-	5000	-	-	-	-
TRCS2-G05-Z /SL-CA 0712	400/3/50	1,69	21,11	58,06	-	5000	-	-	-	-
TRCS2-G05-Z /SL-CA 0853	400/3/50	1,49	24,44	67,22	-	5000	-	-	-	-
TRCS2-G05-Z /SL-CA 0913	400/3/50	1,49	24,44	67,22	-	5000	-	-	-	-
TRCS2-G05-Z /SL-CA 1013	400/3/50	1,05	28,89	80,00	-	5000	-	-	-	-
TRCS2-G05-Z /SL-CA 1054	400/3/50	1,05	32,50	90,28	-	5000	-	-	-	-
TRCS2-G05-Z /SL-CA 1154	400/3/50	0,90	32,50	90,28	-	5000	-	-	-	-
TRCS2-G05-Z /D /SL-CA 0211	400/3/50	22,7	6,389	17,22	-	5000	446	-	3,611	-
TRCS2-G05-Z /D /SL-CA 0251	400/3/50	13,9	8,056	22,22	-	5000	446	-	3,611	-
TRCS2-G05-Z /D /SL-CA 0351	400/3/50	8,04	10,00	27,78	-	5000	217	-	4,861	-
TRCS2-G05-Z /D /SL-CA 0452	400/3/50	4,76	13,89	38,33	-	5000	70,3	-	8,472	-
TRCS2-G05-Z /D /SL-CA 0512	400/3/50	3,61	16,11	44,44	-	5000	70,3	-	8,472	-
TRCS2-G05-Z /D /SL-CA 0552	400/3/50	3,61	16,11	44,44	-	5000	70,3	-	8,472	-
TRCS2-G05-Z /D /SL-CA 0652	400/3/50	1,69	21,11	58,06	-	5000	53,9	-	9,694	-
TRCS2-G05-Z /D /SL-CA 0712	400/3/50	1,69	21,11	58,06	-	5000	53,9	-	9,694	-
TRCS2-G05-Z /D /SL-CA 0853	400/3/50	1,49	24,44	67,22	-	5000	28,6	-	13,33	-
TRCS2-G05-Z /D /SL-CA 0913	400/3/50	1,49	24,44	67,22	-	5000	29,7	-	13,33	-
TRCS2-G05-Z /D /SL-CA 1013	400/3/50	1,05	28,89	80,00	-	5000	24,0	-	14,56	-
TRCS2-G05-Z /D /SL-CA 1054	400/3/50	1,05	32,50	90,28	-	5000	17,6	-	16,94	-
TRCS2-G05-Z /D /SL-CA 1154	400/3/50	0,90	32,50	90,28	-	5000	13,5	-	18,17	-
TRCS2-G05-Z /XL-CA 0211	400/3/50	22,7	6,389	17,22	-	5000	-	-	-	-
TRCS2-G05-Z /XL-CA 0251	400/3/50	13,9	8,056	22,22	-	5000	-	-	-	-
TRCS2-G05-Z /XL-CA 0351	400/3/50	8,04	10,00	27,78	-	5000	-	-	-	-
TRCS2-G05-Z /XL-CA 0452	400/3/50	4,76	13,89	38,33	-	5000	-	-	-	-
TRCS2-G05-Z /XL-CA 0512	400/3/50	3,61	16,11	44,44	-	5000	-	-	-	-
TRCS2-G05-Z /XL-CA 0552	400/3/50	3,61	16,11	44,44	-	5000	-	-	-	-
TRCS2-G05-Z /XL-CA 0652	400/3/50	1,69	21,11	58,06	-	5000	-	-	-	-
TRCS2-G05-Z /XL-CA 0712	400/3/50	1,69	21,11	58,06	-	5000	-	-	-	-
TRCS2-G05-Z /XL-CA 0853	400/3/50	1,49	24,44	67,22	-	5000	-	-	-	-
TRCS2-G05-Z /XL-CA 0913	400/3/50	1,49	24,44	67,22	-	5000	-	-	-	-
TRCS2-G05-Z /XL-CA 1013	400/3/50	1,05	28,89	80,00	-	5000	-	-	-	-
TRCS2-G05-Z /XL-CA 1054	400/3/50	1,05	32,50	90,28	-	5000	-	-	-	-
TRCS2-G05-Z /XL-CA 1154	400/3/50	0,90	32,50	90,28	-	5000	-	-	-	-
TRCS2-G05-Z /D /XL-CA 0211	400/3/50	22,7	6,389	17,22	-	5000	446	-	3,611	-
TRCS2-G05-Z /D /XL-CA 0251	400/3/50	13,9	8,056	22,22	-	5000	446	-	3,611	-

Q min: minimum water flow admitted to the heat exchanger
 Q max: maximum water flow admitted to the heat exchanger
 C.a. min: minimum water content admitted in the plant
 C.A.S.: Exchanger water content

HYDRAULIC DATA

[SI System]

SIZE	Power supply V/ph/Hz	HEAT EXCHANGER USER SIDE					HEAT RECOVERY EX. USER SIDE			
		K	Q min l/s	Q max l/s	C.A.S. l	C.a. min l	K	Q min l/s	Q max l/s	C.A.S. l
TRCS2-G05-Z /D /XL-CA 0351	400/3/50	8,04	10,00	27,78	-	5000	217	-	4,861	-
TRCS2-G05-Z /D /XL-CA 0452	400/3/50	4,76	13,89	38,33	-	5000	70,3	-	8,472	-
TRCS2-G05-Z /D /XL-CA 0512	400/3/50	3,61	16,11	44,44	-	5000	70,3	-	8,472	-
TRCS2-G05-Z /D /XL-CA 0552	400/3/50	3,61	16,11	44,44	-	5000	70,3	-	8,472	-
TRCS2-G05-Z /D /XL-CA 0652	400/3/50	1,69	21,11	58,06	-	5000	53,9	-	9,694	-
TRCS2-G05-Z /D /XL-CA 0712	400/3/50	1,69	21,11	58,06	-	5000	53,9	-	9,694	-
TRCS2-G05-Z /D /XL-CA 0853	400/3/50	1,49	24,44	67,22	-	5000	28,6	-	13,33	-
TRCS2-G05-Z /D /XL-CA 0913	400/3/50	1,49	24,44	67,22	-	5000	29,7	-	13,33	-
TRCS2-G05-Z /D /XL-CA 1013	400/3/50	1,05	28,89	80,00	-	5000	24,0	-	14,56	-
TRCS2-G05-Z /D /XL-CA 1054	400/3/50	1,05	32,50	90,28	-	5000	17,6	-	16,94	-
TRCS2-G05-Z /D /XL-CA 1154	400/3/50	0,90	32,50	90,28	-	5000	13,5	-	18,17	-
TRCS2-G05-Z /SL-CA-E 0211	400/3/50	22,7	6,389	17,22	-	5000	-	-	-	-
TRCS2-G05-Z /SL-CA-E 0251	400/3/50	13,9	8,056	22,22	-	5000	-	-	-	-
TRCS2-G05-Z /SL-CA-E 0351	400/3/50	8,04	10,00	27,78	-	5000	-	-	-	-
TRCS2-G05-Z /SL-CA-E 0452	400/3/50	4,76	13,89	38,33	-	5000	-	-	-	-
TRCS2-G05-Z /SL-CA-E 0512	400/3/50	3,61	16,11	44,44	-	5000	-	-	-	-
TRCS2-G05-Z /SL-CA-E 0552	400/3/50	3,61	16,11	44,44	-	5000	-	-	-	-
TRCS2-G05-Z /SL-CA-E 0652	400/3/50	1,69	21,11	58,06	-	5000	-	-	-	-
TRCS2-G05-Z /SL-CA-E 0712	400/3/50	1,69	21,11	58,06	-	5000	-	-	-	-
TRCS2-G05-Z /SL-CA-E 0853	400/3/50	1,49	24,44	67,22	-	5000	-	-	-	-
TRCS2-G05-Z /SL-CA-E 0913	400/3/50	1,49	24,44	67,22	-	5000	-	-	-	-
TRCS2-G05-Z /SL-CA-E 1013	400/3/50	1,05	28,89	80,00	-	5000	-	-	-	-
TRCS2-G05-Z /SL-CA-E 1054	400/3/50	1,05	32,50	90,28	-	5000	-	-	-	-
TRCS2-G05-Z /SL-CA-E 1154	400/3/50	0,90	32,50	90,28	-	5000	-	-	-	-
TRCS2-G05-Z /D /SL-CA-E 0211	400/3/50	22,7	6,389	17,22	-	5000	446	-	3,611	-
TRCS2-G05-Z /D /SL-CA-E 0251	400/3/50	13,9	8,056	22,22	-	5000	446	-	3,611	-
TRCS2-G05-Z /D /SL-CA-E 0351	400/3/50	8,04	10,00	27,78	-	5000	217	-	4,861	-
TRCS2-G05-Z /D /SL-CA-E 0452	400/3/50	4,76	13,89	38,33	-	5000	70,3	-	8,472	-
TRCS2-G05-Z /D /SL-CA-E 0512	400/3/50	3,61	16,11	44,44	-	5000	70,3	-	8,472	-
TRCS2-G05-Z /D /SL-CA-E 0552	400/3/50	3,61	16,11	44,44	-	5000	70,3	-	8,472	-
TRCS2-G05-Z /D /SL-CA-E 0652	400/3/50	1,69	21,11	58,06	-	5000	53,9	-	9,694	-
TRCS2-G05-Z /D /SL-CA-E 0712	400/3/50	1,69	21,11	58,06	-	5000	53,9	-	9,694	-
TRCS2-G05-Z /D /SL-CA-E 0853	400/3/50	1,49	24,44	67,22	-	5000	28,6	-	13,33	-
TRCS2-G05-Z /D /SL-CA-E 0913	400/3/50	1,49	24,44	67,22	-	5000	29,7	-	13,33	-
TRCS2-G05-Z /D /SL-CA-E 1013	400/3/50	1,05	28,89	80,00	-	5000	24,0	-	14,56	-
TRCS2-G05-Z /D /SL-CA-E 1054	400/3/50	1,05	32,50	90,28	-	5000	17,6	-	16,94	-
TRCS2-G05-Z /D /SL-CA-E 1154	400/3/50	0,90	32,50	90,28	-	5000	13,5	-	18,17	-

Q min: minimum water flow admitted to the heat exchanger
 Q max: maximum water flow admitted to the heat exchanger
 C.a. min: minimum water content admitted in the plant
 C.A.S.: Exchanger water content

10.1 ELECTRICAL DATA
[SI System]

TRCS2-G05-Z/SL-CA

SIZE	Power supply V/ph/Hz	Maximum values								
		Compressor			Fans (1)		Total (1)(2)			
		n	F.L.I. [kW]	F.L.A. [A]	L.R.A. [A]	F.L.I. [kW]	F.L.A. [A]	F.L.I. [kW]	F.L.A. [A]	S.A. [A]
0211	400/3/50	1	1x102	1x160	n.a.	2,000	4	114,0	183	-
0251	400/3/50	1	1x102	1x160	n.a.	2,000	4	114,0	183	-
0351	400/3/50	1	1x148	1x231	n.a.	2,000	4	164,0	262	-
0452	400/3/50	2	2x102	2x160	n.a.	2,000	4	223,0	359	-
0512	400/3/50	2	2x102	2x160	n.a.	2,000	4	223,0	359	-
0552	400/3/50	2	2x102	2x160	n.a.	2,000	4	227,0	367	-
0652	400/3/50	2	2x148	2x231	n.a.	2,000	4	323,0	517	-
0712	400/3/50	2	2x148	2x231	n.a.	2,000	4	323,0	517	-
0853	400/3/50	3	2x102+1x148	2x160+1x231	n.a.	2,000	4	387,0	621	-
0913	400/3/50	3	1x102+2x148	1x160+2x231	n.a.	2,000	4	437,0	700	-
1013	400/3/50	3	3x148	3x231	n.a.	2,000	4	487,0	779	-
1054	400/3/50	4	4x102	4x160	n.a.	2,000	4	455,0	734	-
1154	400/3/50	4	2x102+2x148	2x160+2x231	n.a.	2,000	4	547,0	876	-

F.L.I.: Full load power

F.L.A.: Full load current

L.R.A.: Locked rotor amperes for single compressor

S.A.: Inrush current

(1) Values calculated referring to the version with the maximum number of fans working at the max absorbed current

(1)(2) Safety values to be considered when cabling the unit for power supply and line-protections

Data valid for standard units without any additional option.

Plant (side) cooling exchanger water (in/out) 12,00°C/7,00°C; Source (side) heat exchanger air (in) 35,0°C.

Voltage tolerance: 10%

Maximum voltage unbalance: 3%

Give the typical operating conditions of units designed for outdoor installation, which can be associated (according to reference document IEC 60721) to the following classes:

- climatic conditions class 4K4H: air temperature range from -20 up to 55°C (*), relative humidity range from 4 up to 100%, with possible precipitations, at air pressure from 70 and 106 kPa and a maximum solar radiation of 1120 W/m2

- special climatic conditions negligible

- biological conditions class 4B1 and 4C2: locations in a generic urban area

- mechanically active substances class 4S2: locations in areas with sand or dust representative of urban areas

- mechanical conditions class 4M1: locations protected from significant vibrations or shocks

The required protection level for safe operation, according to reference document IEC 60529, is IP43XW (protection against access, to the most critical unit's parts, of external devices with diameter larger than 1 mm and rain).

The unit can be considered IP44XW protected, i.e. protected against access of external devices (with diameter larger than 1 mm) and water in general.

(*) for the unit's operating limits, see "selection limits" section

ELECTRICAL DATA

TRCS2-G05-Z/XL-CA

[SI System]

SIZE	Power supply V/ph/Hz	Maximum values								
		Compressor			Fans (1)		Total (1)(2)			
		n	F.L.I. [kW]	F.L.A. [A]	L.R.A. [A]	F.L.I. [kW]	F.L.A. [A]	F.L.I. [kW]	F.L.A. [A]	S.A. [A]
0211	400/3/50	1	1x102	1x160	n.a.	2,000	4	114,0	183	-
0251	400/3/50	1	1x102	1x160	n.a.	2,000	4	114,0	183	-
0351	400/3/50	1	1x148	1x231	n.a.	2,000	4	164,0	262	-
0452	400/3/50	2	2x102	2x160	n.a.	2,000	4	223,0	359	-
0512	400/3/50	2	2x102	2x160	n.a.	2,000	4	227,0	367	-
0552	400/3/50	2	2x102	2x160	n.a.	2,000	4	231,0	375	-
0652	400/3/50	2	2x148	2x231	n.a.	2,000	4	323,0	517	-
0712	400/3/50	2	2x148	2x231	n.a.	2,000	4	327,0	524	-
0853	400/3/50	3	2x102+1x148	2x160+1x231	n.a.	2,000	4	391,0	629	-
0913	400/3/50	3	1x102+2x148	1x160+2x231	n.a.	2,000	4	437,0	700	-
1013	400/3/50	3	3x148	3x231	n.a.	2,000	4	487,0	779	-
1054	400/3/50	4	4x102	4x160	n.a.	2,000	4	455,0	734	-
1154	400/3/50	4	2x102+2x148	2x160+2x231	n.a.	2,000	4	550,0	883	-

F.L.I.: Full load power

F.L.A.: Full load current

L.R.A.: Locked rotor amperes for single compressor

S.A.: Inrush current

(1) Values calculated referring to the version with the maximum number of fans working at the max absorbed current

(1)(2) Safety values to be considered when cabling the unit for power supply and line-protections

Data valid for standard units without any additional option.

Plant (side) cooling exchanger water (in/out) 12,00°C/7,00°C; Source (side) heat exchanger air (in) 35,0°C.

Voltage tolerance: 10%

Maximum voltage unbalance: 3%

Give the typical operating conditions of units designed for outdoor installation, which can be associated (according to reference document IEC 60721) to the following classes:

- climatic conditions class 4K4H: air temperature range from -20 up to 55°C (*), relative humidity range from 4 up to 100%, with possible precipitations, at air pressure from 70 and 106 kPa and a maximum solar radiation of 1120 W/m2

- special climatic conditions negligible

- biological conditions class 4B1 and 4C2: locations in a generic urban area

- mechanically active substances class 4S2: locations in areas with sand or dust representative of urban areas

- mechanical conditions class 4M1: locations protected from significant vibrations or shocks

The required protection level for safe operation, according to reference document IEC 60529, is IP43XW (protection against access, to the most critical unit's parts, of external devices with diameter larger than 1 mm and rain).

The unit can be considered IP44XW protected, i.e. protected against access of external devices (with diameter larger than 1 mm) and water in general.

(*) for the unit's operating limits, see "selection limits" section



ELECTRICAL DATA

TRCS2-G05-Z/SL-CA-E

[SI System]

SIZE	Power supply V/ph/Hz	Maximum values								
		Compressor			Fans (1)		Total (1)(2)			
		n	F.L.I. [kW]	F.L.A. [A]	L.R.A. [A]	F.L.I. [kW]	F.L.A. [A]	F.L.I. [kW]	F.L.A. [A]	S.A. [A]
0211	400/3/50	1	1x102	1x160	n.a.	2,000	3	114,0	179	-
0251	400/3/50	1	1x102	1x160	n.a.	2,000	3	114,0	179	-
0351	400/3/50	1	1x148	1x231	n.a.	2,000	3	164,0	256	-
0452	400/3/50	2	2x102	2x160	n.a.	2,000	3	224,0	351	-
0512	400/3/50	2	2x102	2x160	n.a.	2,000	3	224,0	351	-
0552	400/3/50	2	2x102	2x160	n.a.	2,000	3	228,0	357	-
0652	400/3/50	2	2x148	2x231	n.a.	2,000	3	324,0	505	-
0712	400/3/50	2	2x148	2x231	n.a.	2,000	3	328,0	512	-
0853	400/3/50	3	2x102+1x148	2x160+1x231	n.a.	2,000	3	387,0	607	-
0913	400/3/50	3	1x102+2x148	1x160+2x231	n.a.	2,000	3	437,0	684	-
1013	400/3/50	3	3x148	3x231	n.a.	2,000	3	487,0	761	-
1054	400/3/50	4	4x102	4x160	n.a.	2,000	3	455,0	714	-
1154	400/3/50	4	2x102+2x148	2x160+2x231	n.a.	2,000	3	551,0	863	-

F.L.I.: Full load power

F.L.A.: Full load current

L.R.A.: Locked rotor amperes for single compressor

S.A.: Inrush current

(1) Values calculated referring to the version with the maximum number of fans working at the max absorbed current

(1)(2) Safety values to be considered when cabling the unit for power supply and line-protections

Data valid for standard units without any additional option.

Plant (side) cooling exchanger water (in/out) 12,00°C/7,00°C; Source (side) heat exchanger air (in) 35,0°C.

Voltage tolerance: 10%

Maximum voltage unbalance: 3%

Give the typical operating conditions of units designed for outdoor installation, which can be associated (according to reference document IEC 60721) to the following classes:

- climatic conditions class 4K4H: air temperature range from -20 up to 55°C (*), relative humidity range from 4 up to 100%, with possible precipitations, at air pressure from 70 and 106 kPa and a maximum solar radiation of 1120 W/m2

- special climatic conditions negligible

- biological conditions class 4B1 and 4C2: locations in a generic urban area

- mechanically active substances class 4S2: locations in areas with sand or dust representative of urban areas

- mechanical conditions class 4M1: locations protected from significant vibrations or shocks

The required protection level for safe operation, according to reference document IEC 60529, is IP43XW (protection against access, to the most critical unit's parts, of external devices with diameter larger than 1 mm and rain).

The unit can be considered IP44XW protected, i.e. protected against access of external devices (with diameter larger than 1 mm) and water in general.

(*) for the unit's operating limits, see "selection limits" section

11.1 FULL LOAD SOUND LEVEL

TRCS2-G05-Z/SL-CA

SOUND POWER LEVEL IN COOLING									
SIZE	Octave band [Hz]								Total sound level dB(A)
	63	125	250	500	1000	2000	4000	8000	
	Sound power level dB								
0211	86	87	87	84	84	80	75	69	88
0251	86	87	87	84	84	80	75	69	88
0351	88	89	89	86	86	82	77	71	90
0452	88	89	89	86	86	82	77	71	90
0512	88	89	89	86	86	82	77	71	90
0552	89	90	90	87	87	83	78	72	91
0652	90	91	91	88	88	84	79	73	92
0712	90	91	91	88	88	84	79	73	92
0853	91	92	92	89	89	85	80	74	93
0913	91	92	92	89	89	85	80	74	93
1013	91	92	92	89	89	85	80	74	93
1054	92	93	93	90	90	86	81	75	94
1154	92	93	93	90	90	86	81	75	94

Working conditions

Plant (side) cooling exchanger water (in/out) 12,00°C/7,00°C; Source (side) heat exchanger air (in) 35,0°C.

Sound power on the basis of measurements made in compliance with ISO 9614.

Such certification refers specifically to the sound Power Level in dB(A). This is therefore the only acoustic data to be considered as binding.

Sound power level in cooling, outdoors.

SOUND PRESSURE LEVEL									
SIZE	Octave band [Hz]								Total sound level dB(A)
	63	125	250	500	1000	2000	4000	8000	
	Sound pressure level dB								
0211	54	55	55	52	52	48	43	37	56
0251	54	55	55	52	52	48	43	37	56
0351	56	57	57	54	54	50	45	39	58
0452	56	57	57	54	54	50	45	39	58
0512	56	57	57	54	54	50	45	39	58
0552	57	58	58	55	55	51	46	40	59
0652	57	58	58	55	55	51	46	40	59
0712	57	58	58	55	55	51	46	40	59
0853	58	59	59	56	56	52	47	41	60
0913	58	59	59	56	56	52	47	41	60
1013	58	59	59	56	56	52	47	41	60
1054	59	60	60	57	57	53	48	42	61
1154	59	60	60	57	57	53	48	42	61

Working conditions

Plant (side) cooling exchanger water (in/out) 12,00°C/7,00°C; Source (side) heat exchanger air (in) 35,0°C.

Average sound pressure level at 10m distance, unit in a free field on a reflective surface; non-binding value calculated from the sound power level.

FULL LOAD SOUND LEVEL

TRCS2-G05-Z/XL-CA

SOUND POWER LEVEL IN COOLING									
SIZE	Octave band [Hz]								Total sound level dB(A)
	63	125	250	500	1000	2000	4000	8000	
	Sound power level dB								
0211	83	81	81	78	77	75	71	67	82
0251	83	81	81	78	77	75	71	67	82
0351	86	81	80	77	76	77	75	69	83
0452	84	82	82	79	78	76	72	68	83
0512	85	83	83	80	79	77	73	69	84
0552	86	84	84	81	80	78	74	70	85
0652	88	83	82	79	78	79	77	71	85
0712	89	84	83	80	79	80	78	72	86
0853	87	85	85	82	81	79	75	71	86
0913	89	84	83	80	79	80	78	72	86
1013	90	85	84	81	80	81	79	73	87
1054	88	86	86	83	82	80	76	72	87
1154	90	87	86	83	82	82	79	74	88

Working conditions

Plant (side) cooling exchanger water (in/out) 12,00°C/7,00°C; Source (side) heat exchanger air (in) 35,0°C.

Sound power on the basis of measurements made in compliance with ISO 9614.

Such certification refers specifically to the sound Power Level in dB(A). This is therefore the only acoustic data to be considered as binding.

Sound power level in cooling, outdoors.

SOUND PRESSURE LEVEL									
SIZE	Octave band [Hz]								Total sound level dB(A)
	63	125	250	500	1000	2000	4000	8000	
	Sound pressure level dB								
0211	51	49	49	46	45	43	39	35	50
0251	51	49	49	46	45	43	39	35	50
0351	54	49	48	45	44	45	43	37	51
0452	52	50	50	47	46	44	40	36	51
0512	53	51	51	48	47	45	41	37	52
0552	53	51	51	48	47	45	41	37	52
0652	55	50	49	46	45	46	44	38	52
0712	56	51	50	47	46	47	45	39	53
0853	54	52	52	49	48	46	42	38	53
0913	56	51	50	47	46	47	45	39	53
1013	57	52	51	48	47	48	46	40	54
1054	55	53	53	50	49	47	43	39	54
1154	57	54	53	50	49	49	46	41	55

Working conditions

Plant (side) cooling exchanger water (in/out) 12,00°C/7,00°C; Source (side) heat exchanger air (in) 35,0°C.

Average sound pressure level at 10m distance, unit in a free field on a reflective surface; non-binding value calculated from the sound power level.

FULL LOAD SOUND LEVEL

TRCS2-G05-Z/SL-CA-E

SOUND POWER LEVEL IN COOLING									
SIZE	Octave band [Hz]								Total sound level dB(A)
	63	125	250	500	1000	2000	4000	8000	
	Sound power level dB								
0211	86	87	87	84	84	80	75	69	88
0251	86	87	87	84	84	80	75	69	88
0351	88	89	89	86	86	82	77	71	90
0452	88	89	89	86	86	82	77	71	90
0512	88	89	89	86	86	82	77	71	90
0552	89	90	90	87	87	83	78	72	91
0652	90	91	91	88	88	84	79	73	92
0712	90	91	91	88	88	84	79	73	92
0853	91	92	92	89	89	85	80	74	93
0913	91	92	92	89	89	85	80	74	93
1013	91	92	92	89	89	85	80	74	93
1054	92	93	93	90	90	86	81	75	94
1154	93	94	94	91	91	87	82	76	95

Working conditions

Plant (side) cooling exchanger water (in/out) 12,00°C/7,00°C; Source (side) heat exchanger air (in) 35,0°C.

Sound power on the basis of measurements made in compliance with ISO 9614.

Such certification refers specifically to the sound Power Level in dB(A). This is therefore the only acoustic data to be considered as binding.

Sound power level in cooling, outdoors.

SOUND PRESSURE LEVEL									
SIZE	Octave band [Hz]								Total sound level dB(A)
	63	125	250	500	1000	2000	4000	8000	
	Sound pressure level dB								
0211	54	55	55	52	52	48	43	37	56
0251	54	55	55	52	52	48	43	37	56
0351	56	57	57	54	54	50	45	39	58
0452	56	57	57	54	54	50	45	39	58
0512	56	57	57	54	54	50	45	39	58
0552	57	58	58	55	55	51	46	40	59
0652	57	58	58	55	55	51	46	40	59
0712	57	58	58	55	55	51	46	40	59
0853	58	59	59	56	56	52	47	41	60
0913	58	59	59	56	56	52	47	41	60
1013	58	59	59	56	56	52	47	41	60
1054	59	60	60	57	57	53	48	42	61
1154	60	61	61	58	58	54	49	43	62

Working conditions

Plant (side) cooling exchanger water (in/out) 12,00°C/7,00°C; Source (side) heat exchanger air (in) 35,0°C.

Average sound pressure level at 10m distance, unit in a free field on a reflective surface; non-binding value calculated from the sound power level.

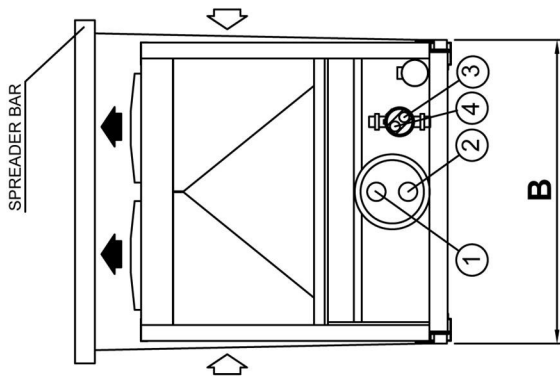

- ① EVAPORATOR WATER INLET
ENTRATA ACQUA EVAPORATORE
- ② EVAPORATOR WATER OUTLET
USCITA ACQUA EVAPORATORE
- ③ DESUPERHEATER WATER INLET
ENTRATA ACQUA DESURRISCALDATORE
- ④ DESUPERHEATER WATER OUTLET
USCITA ACQUA DESURRISCALDATORE
- ⑤ LIFTING POINTS
PUNTI DI SOLLEVAMENTO
- ⑥ POWER CABLE INLET
ENTRATA LINEA ELETTRICA

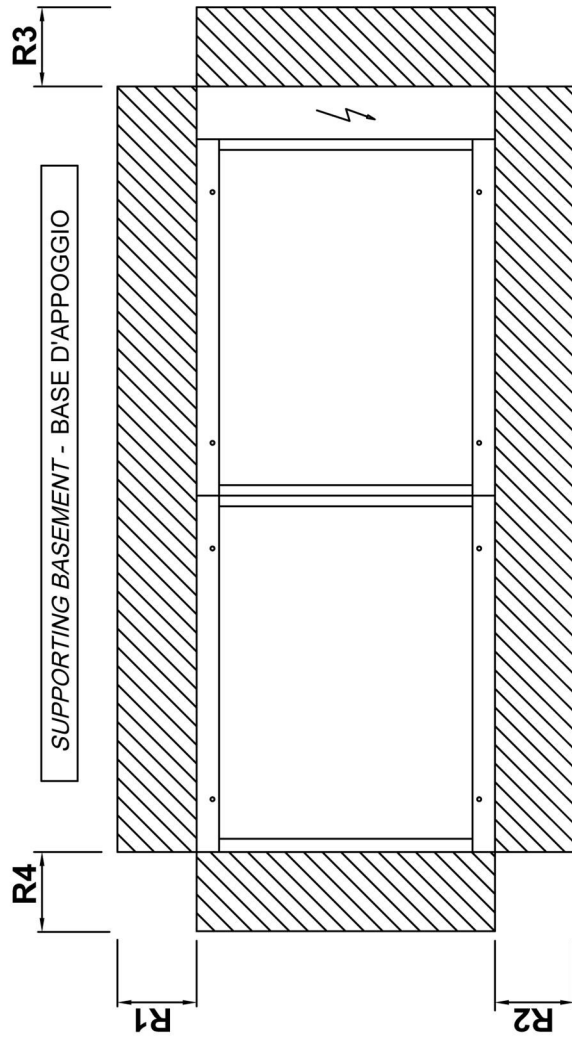
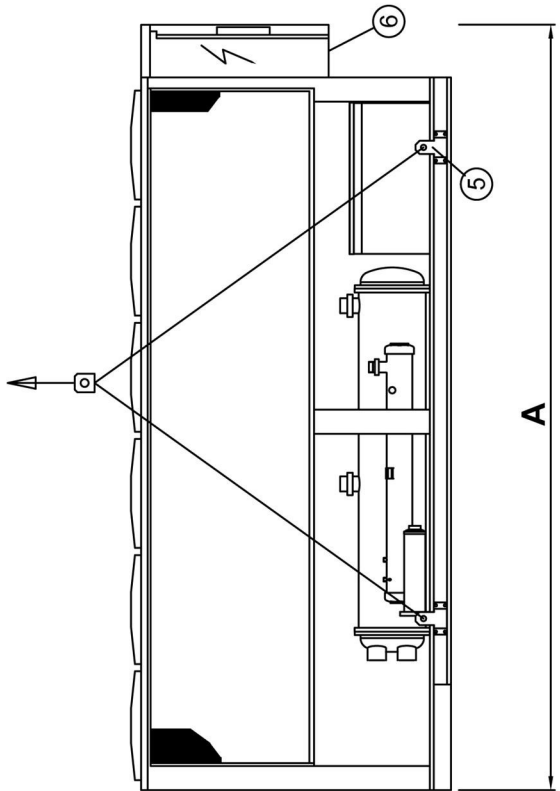

DIMENSIONAL DRAWINGS
[SI System]

TRCS2-G05-Z 0211 - 1154

SIZE	DIMENSIONS AND WEIGHTS				CLEARANCE				HEAT EXCHANGER USER SIDE		HEAT RECOVERY EX. USER SIDE	
	A	B	H WEIGHT		R1	R2	R3	R4	IN/OUT		IN/OUT	
	[mm]	[mm]	[mm]	[kg]	[mm]	[mm]	[mm]	[mm]	TYPE	Ø	TYPE	Ø
TRCS2-G05-Z /SL-CA 0211	3100	2260	2430	2320	2000	2000	1800	1500	VICTAULIC	4"	-	-
TRCS2-G05-Z /SL-CA 0251	3100	2260	2430	2370	2000	2000	1800	1500	VICTAULIC	4"	-	-
TRCS2-G05-Z /SL-CA 0351	4000	2260	2430	3050	2000	2000	1800	1500	VICTAULIC	4"	-	-
TRCS2-G05-Z /SL-CA 0452	4900	2260	2430	4000	2000	2000	1800	1500	VICTAULIC	5"	-	-
TRCS2-G05-Z /SL-CA 0512	4900	2260	2430	4240	2000	2000	1800	1500	VICTAULIC	5"	-	-
TRCS2-G05-Z /SL-CA 0552	5800	2260	2430	4530	2000	2000	1800	1500	VICTAULIC	5"	-	-
TRCS2-G05-Z /SL-CA 0652	7000	2260	2430	5800	2000	2000	1800	1500	VICTAULIC	6"	-	-
TRCS2-G05-Z /SL-CA 0712	7000	2260	2430	6150	2000	2000	1800	1500	VICTAULIC	6"	-	-
TRCS2-G05-Z /SL-CA 0853	8500	2260	2430	6940	2000	2000	1800	1500	VICTAULIC	8"	-	-
TRCS2-G05-Z /SL-CA 0913	9700	2260	2430	7370	2000	2000	1800	1500	VICTAULIC	8"	-	-
TRCS2-G05-Z /SL-CA 1013	10600	2260	2430	8150	2000	2000	1800	1500	VICTAULIC	8"	-	-
TRCS2-G05-Z /SL-CA 1054	11200	2260	2430	8700	2000	2000	1800	1500	VICTAULIC	8"	-	-
TRCS2-G05-Z /SL-CA 1154	11500	2260	2430	9020	2000	2000	1800	1500	VICTAULIC	8"	-	-
TRCS2-G05-Z /D /SL-CA 0211	3100	2260	2430	2400	2000	2000	1800	1500	VICTAULIC	4"	GAS	1" 1/2
TRCS2-G05-Z /D /SL-CA 0251	3100	2260	2430	2450	2000	2000	1800	1500	VICTAULIC	4"	GAS	1" 1/2
TRCS2-G05-Z /D /SL-CA 0351	4000	2260	2430	3150	2000	2000	1800	1500	VICTAULIC	4"	GAS	1" 1/2
TRCS2-G05-Z /D /SL-CA 0452	4900	2260	2430	4150	2000	2000	1800	1500	VICTAULIC	5"	GAS	2" 1/2
TRCS2-G05-Z /D /SL-CA 0512	4900	2260	2430	4390	2000	2000	1800	1500	VICTAULIC	5"	GAS	2" 1/2
TRCS2-G05-Z /D /SL-CA 0552	5800	2260	2430	4680	2000	2000	1800	1500	VICTAULIC	5"	GAS	2" 1/2
TRCS2-G05-Z /D /SL-CA 0652	7000	2260	2430	5970	2000	2000	1800	1500	VICTAULIC	6"	GAS	2" 1/2
TRCS2-G05-Z /D /SL-CA 0712	7000	2260	2430	6320	2000	2000	1800	1500	VICTAULIC	6"	GAS	2" 1/2
TRCS2-G05-Z /D /SL-CA 0853	8500	2260	2430	7190	2000	2000	1800	1500	VICTAULIC	8"	GAS	2" 1/2
TRCS2-G05-Z /D /SL-CA 0913	9700	2260	2430	7620	2000	2000	1800	1500	VICTAULIC	8"	GAS	2" 1/2
TRCS2-G05-Z /D /SL-CA 1013	10600	2260	2430	8420	2000	2000	1800	1500	VICTAULIC	8"	GAS	2" 1/2
TRCS2-G05-Z /D /SL-CA 1054	11200	2260	2430	9000	2000	2000	1800	1500	VICTAULIC	8"	GAS	2" 1/2
TRCS2-G05-Z /D /SL-CA 1154	11500	2260	2430	9360	2000	2000	1800	1500	VICTAULIC	8"	GAS	2" 1/2
TRCS2-G05-Z /XL-CA 0211	3100	2260	2430	2370	2000	2000	1800	1500	VICTAULIC	4"	-	-
TRCS2-G05-Z /XL-CA 0251	3100	2260	2430	2420	2000	2000	1800	1500	VICTAULIC	4"	-	-
TRCS2-G05-Z /XL-CA 0351	4000	2260	2430	3200	2000	2000	1800	1500	VICTAULIC	4"	-	-
TRCS2-G05-Z /XL-CA 0452	4900	2260	2430	4240	2000	2000	1800	1500	VICTAULIC	5"	-	-
TRCS2-G05-Z /XL-CA 0512	5800	2260	2430	4690	2000	2000	1800	1500	VICTAULIC	5"	-	-
TRCS2-G05-Z /XL-CA 0552	7000	2260	2430	5350	2000	2000	1800	1500	VICTAULIC	5"	-	-
TRCS2-G05-Z /XL-CA 0652	7000	2260	2430	6150	2000	2000	1800	1500	VICTAULIC	6"	-	-
TRCS2-G05-Z /XL-CA 0712	7900	2260	2430	6650	2000	2000	1800	1500	VICTAULIC	6"	-	-
TRCS2-G05-Z /XL-CA 0853	9400	2260	2430	7520	2000	2000	1800	1500	VICTAULIC	8"	-	-
TRCS2-G05-Z /XL-CA 0913	9700	2260	2430	7770	2000	2000	1800	1500	VICTAULIC	8"	-	-
TRCS2-G05-Z /XL-CA 1013	10600	2260	2430	8650	2000	2000	1800	1500	VICTAULIC	8"	-	-
TRCS2-G05-Z /XL-CA 1054	11200	2260	2430	9150	2000	2000	1800	1500	VICTAULIC	8"	-	-
TRCS2-G05-Z /XL-CA 1154	12400	2260	2430	9960	2000	2000	1800	1500	VICTAULIC	8"	-	-
TRCS2-G05-Z /D /XL-CA 0211	3100	2260	2430	2450	2000	2000	1800	1500	VICTAULIC	4"	GAS	1" 1/2
TRCS2-G05-Z /D /XL-CA 0251	3100	2260	2430	2500	2000	2000	1800	1500	VICTAULIC	4"	GAS	1" 1/2
TRCS2-G05-Z /D /XL-CA 0351	4000	2260	2430	3300	2000	2000	1800	1500	VICTAULIC	4"	GAS	1" 1/2
TRCS2-G05-Z /D /XL-CA 0452	4900	2260	2430	4390	2000	2000	1800	1500	VICTAULIC	5"	GAS	2" 1/2
TRCS2-G05-Z /D /XL-CA 0512	5800	2260	2430	4840	2000	2000	1800	1500	VICTAULIC	5"	GAS	2" 1/2
TRCS2-G05-Z /D /XL-CA 0552	7000	2260	2430	5500	2000	2000	1800	1500	VICTAULIC	5"	GAS	2" 1/2
TRCS2-G05-Z /D /XL-CA 0652	7000	2260	2430	6320	2000	2000	1800	1500	VICTAULIC	6"	GAS	2" 1/2
TRCS2-G05-Z /D /XL-CA 0712	7900	2260	2430	6820	2000	2000	1800	1500	VICTAULIC	6"	GAS	2" 1/2
TRCS2-G05-Z /D /XL-CA 0853	9400	2260	2430	7770	2000	2000	1800	1500	VICTAULIC	8"	GAS	2" 1/2
TRCS2-G05-Z /D /XL-CA 0913	9700	2260	2430	8020	2000	2000	1800	1500	VICTAULIC	8"	GAS	2" 1/2
TRCS2-G05-Z /D /XL-CA 1013	10600	2260	2430	8920	2000	2000	1800	1500	VICTAULIC	8"	GAS	2" 1/2
TRCS2-G05-Z /D /XL-CA 1054	11200	2260	2430	9450	2000	2000	1800	1500	VICTAULIC	8"	GAS	2" 1/2
TRCS2-G05-Z /D /XL-CA 1154	12400	2260	2430	10300	2000	2000	1800	1500	VICTAULIC	8"	GAS	2" 1/2



DIMENSIONAL DRAWINGS
[SI System]

TRCS2-G05-Z 0211 - 1154

SIZE	DIMENSIONS AND WEIGHTS				CLEARANCE				HEAT EXCHANGER USER SIDE		HEAT RECOVERY EX. USER SIDE	
	A	B	H WEIGHT		R1	R2	R3	R4	IN/OUT		IN/OUT	
	[mm]	[mm]	[mm]	[kg]	[mm]	[mm]	[mm]	[mm]	TYPE	Ø	TYPE	Ø
TRCS2-G05-Z /SL-CA-E 0211	3100	2260	2430	2270	2000	2000	1800	1500	VICTAULIC	4"	-	-
TRCS2-G05-Z /SL-CA-E 0251	3100	2260	2430	2350	2000	2000	1800	1500	VICTAULIC	4"	-	-
TRCS2-G05-Z /SL-CA-E 0351	4000	2260	2430	3130	2000	2000	1800	1500	VICTAULIC	4"	-	-
TRCS2-G05-Z /SL-CA-E 0452	4900	2260	2430	4070	2000	2000	1800	1500	VICTAULIC	5"	-	-
TRCS2-G05-Z /SL-CA-E 0512	4900	2260	2430	4230	2000	2000	1800	1500	VICTAULIC	5"	-	-
TRCS2-G05-Z /SL-CA-E 0552	5800	2260	2430	4570	2000	2000	1800	1500	VICTAULIC	5"	-	-
TRCS2-G05-Z /SL-CA-E 0652	7000	2260	2430	6040	2000	2000	1800	1500	VICTAULIC	6"	-	-
TRCS2-G05-Z /SL-CA-E 0712	7900	2260	2430	6450	2000	2000	1800	1500	VICTAULIC	6"	-	-
TRCS2-G05-Z /SL-CA-E 0853	8500	2260	2430	7020	2000	2000	1800	1500	VICTAULIC	8"	-	-
TRCS2-G05-Z /SL-CA-E 0913	9700	2260	2430	7610	2000	2000	1800	1500	VICTAULIC	8"	-	-
TRCS2-G05-Z /SL-CA-E 1013	10600	2260	2430	8510	2000	2000	1800	1500	VICTAULIC	8"	-	-
TRCS2-G05-Z /SL-CA-E 1054	11200	2260	2430	8660	2000	2000	1800	1500	VICTAULIC	8"	-	-
TRCS2-G05-Z /SL-CA-E 1154	12400	2260	2430	9720	2000	2000	1800	1500	VICTAULIC	8"	-	-
TRCS2-G05-Z /D /SL-CA-E 0211	3100	2260	2430	2350	2000	2000	1800	1500	VICTAULIC	4"	GAS	1" 1/2
TRCS2-G05-Z /D /SL-CA-E 0251	3100	2260	2430	2430	2000	2000	1800	1500	VICTAULIC	4"	GAS	1" 1/2
TRCS2-G05-Z /D /SL-CA-E 0351	4000	2260	2430	3230	2000	2000	1800	1500	VICTAULIC	4"	GAS	1" 1/2
TRCS2-G05-Z /D /SL-CA-E 0452	4900	2260	2430	4220	2000	2000	1800	1500	VICTAULIC	5"	GAS	2" 1/2
TRCS2-G05-Z /D /SL-CA-E 0512	4900	2260	2430	4380	2000	2000	1800	1500	VICTAULIC	5"	GAS	2" 1/2
TRCS2-G05-Z /D /SL-CA-E 0552	5800	2260	2430	4720	2000	2000	1800	1500	VICTAULIC	5"	GAS	2" 1/2
TRCS2-G05-Z /D /SL-CA-E 0652	7000	2260	2430	6210	2000	2000	1800	1500	VICTAULIC	6"	GAS	2" 1/2
TRCS2-G05-Z /D /SL-CA-E 0712	7900	2260	2430	6620	2000	2000	1800	1500	VICTAULIC	6"	GAS	2" 1/2
TRCS2-G05-Z /D /SL-CA-E 0853	8500	2260	2430	7270	2000	2000	1800	1500	VICTAULIC	8"	GAS	2" 1/2
TRCS2-G05-Z /D /SL-CA-E 0913	9700	2260	2430	7860	2000	2000	1800	1500	VICTAULIC	8"	GAS	2" 1/2
TRCS2-G05-Z /D /SL-CA-E 1013	10600	2260	2430	8780	2000	2000	1800	1500	VICTAULIC	8"	GAS	2" 1/2
TRCS2-G05-Z /D /SL-CA-E 1054	11200	2260	2430	8960	2000	2000	1800	1500	VICTAULIC	8"	GAS	2" 1/2
TRCS2-G05-Z /D /SL-CA-E 1154	12400	2260	2430	10060	2000	2000	1800	1500	VICTAULIC	8"	GAS	2" 1/2

Pipe threads where pressure-tight joints are not made on the threads - Designation, dimensions and tolerances.

Used terminology:

- G: Pipe threads where pressure-tight joints are not made on the threads
- A: Close tolerance class for external pipe threads where pressure-tight joints are not made on the threads
- B: Wider tolerance class for external pipe threads where pressure-tight joints are not made on the threads

Internal threads: G letter followed by thread mark (only tolerance class)
 External threads: G letter followed by thread mark and by A letter for A class external threads or by B letter for B class external threads.

Pipe threads where pressure-tight joints are made on the threads - Designation, dimensions and tolerances.

Used terminology:

- Rp: Internal cylindrical threads where pressure-tight joints are made on the threads
- Rc: Internal conical threads where pressure-tight joints are made on the threads
- R: External conical threads where pressure-tight joints are made on the threads

Internal cylindrical threads: R letter followed by p letter
 Internal conical threads: R letter followed by c letter
 External conical threads: R letter

Designation	Description
UNI ISO 7/1 - Rp 1 1/2	Internal cylindrical threads where pressure-tight joints are made on the threads, defined by standard UNI ISO 7/1 Conventional \varnothing 1 1/2"
UNI ISO 7/1 - Rp 2 1/2	Internal cylindrical threads where pressure-tight joints are made on the threads, defined by standard UNI ISO 7/1 Conventional \varnothing 2 1/2"
UNI ISO 7/1 - Rp 3	Internal cylindrical threads where pressure-tight joints are made on the threads, defined by standard UNI ISO 7/1 Conventional \varnothing 3"
UNI ISO 7/1 - R 3	External conical threads where pressure-tight joints are made on the threads, defined by standard UNI ISO 7/1 Conventional \varnothing 3"
UNI ISO 228/1 - G 4 B	Internal cylindrical threads where pressure-tight joints are not made on the threads, defined by standard UNI ISO 228/1 Tolerance class B for external thread Conventional \varnothing 4"
DN 80 PN 16	Flange Nominal Diameter: 80 mm th. Nominal Pressure: 16 bar

Notes:

Conventional diameter value [in inches] identifies short thread designation, based upon the relative standard.
 All relative values are defined by standards.
 As example, here below some values:

	UNI ISO 7/1	UNI ISO 228/1
Conventional \varnothing	1"	1"
Pitch	2.309 mm	2.309 mm
External \varnothing	33.249 mm	33.249 mm
Core \varnothing	30.291 mm	30.291 mm
Thread height	1.479 mm	1.479 mm

13.1 HYDRONIC GROUP

Possible configurations

PUMP GROUP	Versions		
	SL-CA	SL-CA-E	XL-CA
2 PUMPS 4 POLES (2EV LH)(3183)	X	X	X
2 PUMPS 4 POLES (2EV HH)(3184)	X	X	X

HYDRONIC GROUP

Hydronic kit positioning

	Version	2 PUMPS 4 POLES (2EV LH) (3183)				2 PUMPS 4 POLES (2EV HH) (3184)											
		extra L [mm]	extra W [mm]	extra H [mm]	extra WGT [kg]	extra L [mm]	extra W [mm]	extra H [mm]	extra WGT [kg]	extra L [mm]	extra W [mm]	extra H [mm]	extra WGT [kg]	extra L [mm]	extra W [mm]	extra H [mm]	extra WGT [kg]
0211	SL-CA	/	/	/	-	/	/	/	-								
	SL-CA-E	/	/	/	-	/	/	/	-								
	XL-CA	/	/	/	-	/	/	/	-								
0251	SL-CA	/	/	/	-	/	/	/	-								
	SL-CA-E	/	/	/	-	/	/	/	-								
	XL-CA	/	/	/	-	/	/	/	-								
0351	SL-CA	/	/	/	-	/	/	/	-								
	SL-CA-E	/	/	/	-	/	/	/	-								
	XL-CA	/	/	/	-	/	/	/	-								
0452	SL-CA	/	/	/	-	/	/	/	-								
	SL-CA-E	/	/	/	-	/	/	/	-								
	XL-CA	/	/	/	-	/	/	/	-								
0512	SL-CA	/	/	/	-	/	/	/	-								
	SL-CA-E	/	/	/	-	/	/	/	-								
	XL-CA	/	/	/	-	/	/	/	-								
0552	SL-CA	/	/	/	-	/	/	/	-								
	SL-CA-E	/	/	/	-	/	/	/	-								
	XL-CA	/	/	/	-	/	/	/	-								
0652	SL-CA	/	/	/	-	/	/	/	-								
	SL-CA-E	/	/	/	-	/	/	/	-								
	XL-CA	/	/	/	-	/	/	/	-								
0712	SL-CA	/	/	/	-	/	/	/	-								
	SL-CA-E	/	/	/	-	/	/	/	-								
	XL-CA	/	/	/	-	/	/	/	-								
0853	SL-CA	/	/	/	-	/	/	/	-								
	SL-CA-E	/	/	/	-	/	/	/	-								
	XL-CA	/	/	/	-	/	/	/	-								
0913	SL-CA	/	/	/	-	/	/	/	-								
	SL-CA-E	/	/	/	-	/	/	/	-								
	XL-CA	/	/	/	-	/	/	/	-								
1013	SL-CA	/	/	/	-	/	/	/	-								
	SL-CA-E	/	/	/	-	/	/	/	-								
	XL-CA	/	/	/	-	/	/	/	-								
1054	SL-CA	/	/	/	-	/	/	/	-								
	SL-CA-E	/	/	/	-	/	/	/	-								
	XL-CA	/	/	/	-	/	/	/	-								
1154	SL-CA	/	/	/	-	/	/	/	-								
	SL-CA-E	/	/	/	-	/	/	/	-								
	XL-CA	/	/	/	-	/	/	/	-								

- extra L** Unit's extra length
- extra W** Unit's extra operating width (NOT to be considered for transport)
- extra H** Unit's extra height
- extra H** Unit's extra weight (pumps and piping)
- 2 PUMPS 4 POLES (2EV LH)** 2 PUMPS 4 POLES (2EV LH)
- 2 PUMPS 4 POLES (2EV HH)** 2 PUMPS 4 POLES (2EV HH)
- Not available

HYDRONIC GROUP

HEAT EXCHANGER USER SIDE - 2 PUMPS 4 POLES (2EV HH)

SIZE		CH		PUMP					CH
		Pfgross	Qfgross	Rif.	Model	N.	F.L.A.	F.L.I.	HU
		[kW] (1)	[l/s] (1)			Pole	[A]	[kW]	[kPa]
0211	SL-CA	230,4	11,02	A1					213
	SL-CA-E	226,4	10,83						215
	XL-CA	217,9	10,42						219
0251	SL-CA	255,9	12,24	A2	NSCS 65-315/75/4	4	14	7,500	215
	SL-CA-E	282,8	13,52						202
	XL-CA	252,4	12,07						217
0351	SL-CA	343,3	16,42	C1	NSCS 65-315/110/4	4	21	11,00	238
	SL-CA-E	381,9	18,26		NSCS 65-315/75/4	4	14	7,500	188
	XL-CA	338,6	16,19						218
0452	SL-CA	437,9	20,94	D1	NSCS 65-315/110/4	4	21	11,00	210
	SL-CA-E	450,5	21,55						223
	XL-CA	431,0	20,61						199
0512	SL-CA	502,5	24,03	E1	NSCS 80-315/110/4	4	21	11,00	193
	SL-CA-E	520,5	24,89						194
	XL-CA	519,2	24,83						177
0552	SL-CA	567,3	27,13	E2					171
	SL-CA-E	583,5	27,90						175
	XL-CA	573,0	27,40						229
0652	SL-CA	643,1	30,76	F1	NSCS 80-315/150/4	4	31	15,00	211
	SL-CA-E	695,8	33,27						232
	XL-CA	634,0	30,32						197
0712	SL-CA	733,3	35,07	F2					175
	SL-CA-E	786,2	37,60						198
	XL-CA	730,0	34,91						190
0853	SL-CA	840,5	40,19	G1	NSCS 100-315/150/4	4	28	15,00	177
	SL-CA-E	894,0	42,75						184
	XL-CA	865,8	41,40						213
0913	SL-CA	891,7	42,64	H1	NSCS 100-315/185/4	4	35	18,50	196
	SL-CA-E	956,7	45,75						214
	XL-CA	888,0	42,47						206
1013	SL-CA	964,6	46,13	H2					178
	SL-CA-E	1071	51,24						207
	XL-CA	959,1	45,87						219
1054	SL-CA	1056	50,52	I1	NSCS 100-315/220/4	4	41	22,00	188
	SL-CA-E	1168	55,85						223
	XL-CA	1040	49,75						211
1154	SL-CA	1173	56,08	J1	NSCS 125-315/220/4	4	41	22,00	185
	SL-CA-E	1313	62,77						213
	XL-CA	1163	55,63						

(1) Values refer to nominal conditions
 CH Cooling mode
 Pf Cooling capacity unit (Cooling mode)
 Pt Heating capacity unit (Heating mode)

Q Plant (side) exchanger water flow
 F.L.I. Pump power input
 F.L.A. Pump running current
 HU Pump residual pressure head (Units with hydronic group without mains filter)

HEAT EXCHANGER USER SIDE - 2 PUMPS 4 POLES (2EV HH)

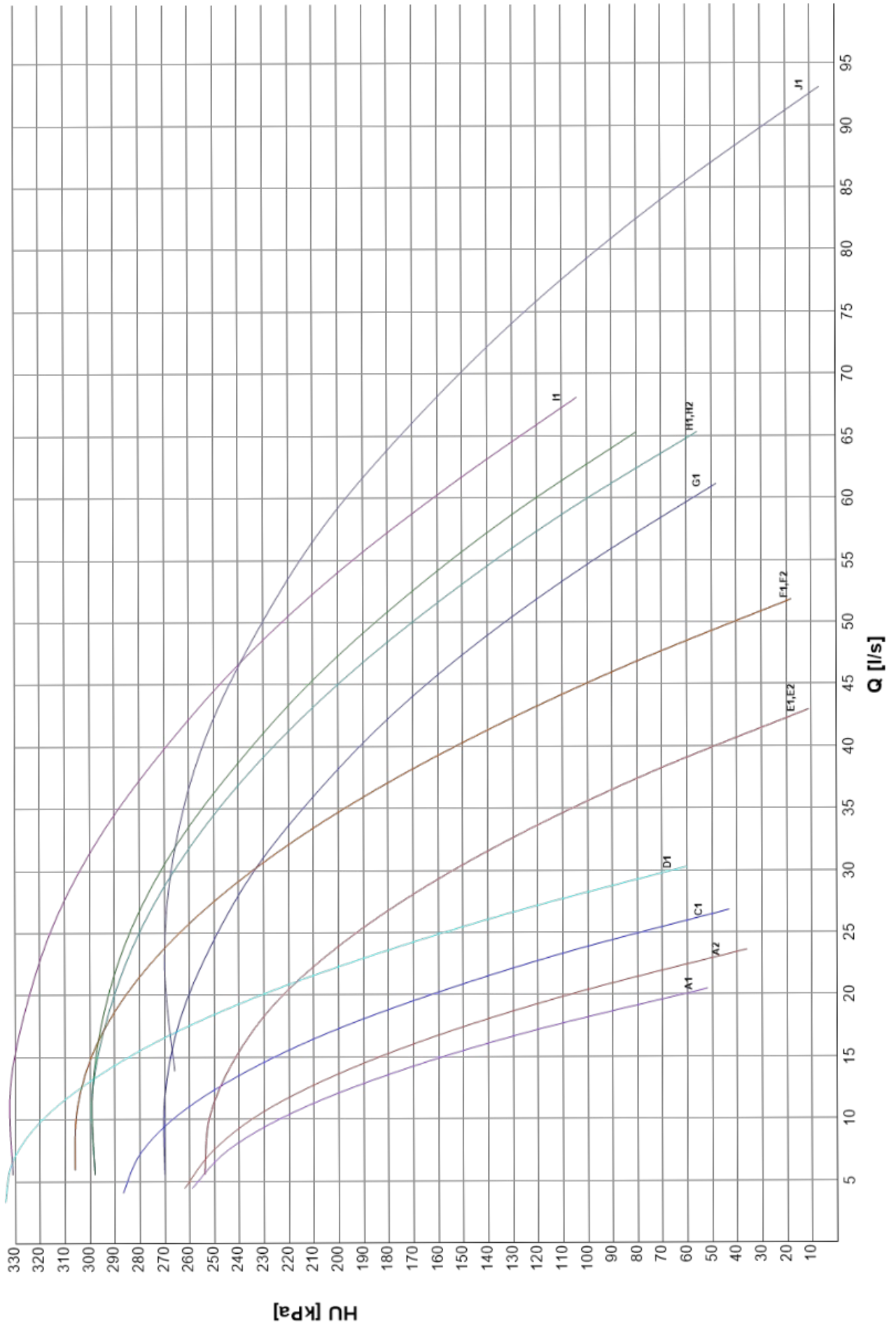

HYDRONIC GROUP

HEAT EXCHANGER USER SIDE - 2 PUMPS 4 POLES (2EV LH)

SIZE		CH		PUMP					CH
		Pfgross	Qfgross	Rif.	Model	N.	F.L.A.	F.L.I.	HU
		[kW] (1)	[l/s] (1)			Pole	[A]	[kW]	[kPa]
0211	SL-CA	230,4	11,02	A1	NSCE 50-250/30/4	4	7	3,000	93,7
	SL-CA-E	226,4	10,83						97,5
	XL-CA	217,9	10,42						105
0251	SL-CA	255,9	12,24	B1	NSCS 65-250/40/4	4	8	4,000	111
	SL-CA-E	282,8	13,52						98,2
	XL-CA	252,4	12,07						113
0351	SL-CA	343,3	16,42	C1	NSCS 65-250/55/4	4	10	5,500	137
	SL-CA-E	381,9	18,26						117
	XL-CA	338,6	16,19						139
0452	SL-CA	437,9	20,94	D1	NSCS 80-250/55/4	4	10	5,500	125
	SL-CA-E	450,5	21,55						121
	XL-CA	431,0	20,61						127
0512	SL-CA	502,5	24,03	D2	NSCS 80-250/55/4	4	10	5,500	113
	SL-CA-E	520,5	24,89						107
	XL-CA	519,2	24,83						108
0552	SL-CA	567,3	27,13	E1	NSCS 80-250/75/4	4	14	7,500	119
	SL-CA-E	583,5	27,90						113
	XL-CA	573,0	27,40						117
0652	SL-CA	643,1	30,76	E2	NSCS 80-250/75/4	4	14	7,500	113
	SL-CA-E	695,8	33,27						94,4
	XL-CA	634,0	30,32						116
0712	SL-CA	733,3	35,07	F1	NSCS 100-250/75/4	4	15	7,500	111
	SL-CA-E	786,2	37,60						99,3
	XL-CA	730,0	34,91						111
0853	SL-CA	840,5	40,19	G1	NSCS 100-250/110/4	4	21	11,00	131
	SL-CA-E	894,0	42,75						118
	XL-CA	865,8	41,40						125
0913	SL-CA	891,7	42,64	G2	NSCS 100-250/110/4	4	21	11,00	119
	SL-CA-E	956,7	45,75						102
	XL-CA	888,0	42,47						120
1013	SL-CA	964,6	46,13	I1	NSCS 100-315/150/4	4	28	15,00	112
	SL-CA-E	1071	51,24						140
	XL-CA	959,1	45,87						113
1054	SL-CA	1056	50,52	L1	NSCS 100-315/150/4	4	28	15,00	144
	SL-CA-E	1168	55,85						149
	XL-CA	1040	49,75						149
1154	SL-CA	1173	56,08	M1	NSCS 125-250/150/4	4	28	15,00	150
	SL-CA-E	1313	62,77						128
	XL-CA	1163	55,63						151

(1) Values refer to nominal conditions
 CH Cooling mode
 Pf Cooling capacity unit (Cooling mode)
 Pt Heating capacity unit (Heating mode)

Q Plant (side) exchanger water flow
 F.L.I. Pump power input
 F.L.A. Pump running current
 HU Pump residual pressure head (Units with hydronic group without mains filter)

HYDRONIC GROUP

HEAT EXCHANGER USER SIDE - 2 PUMPS 4 POLES (2EV LH)

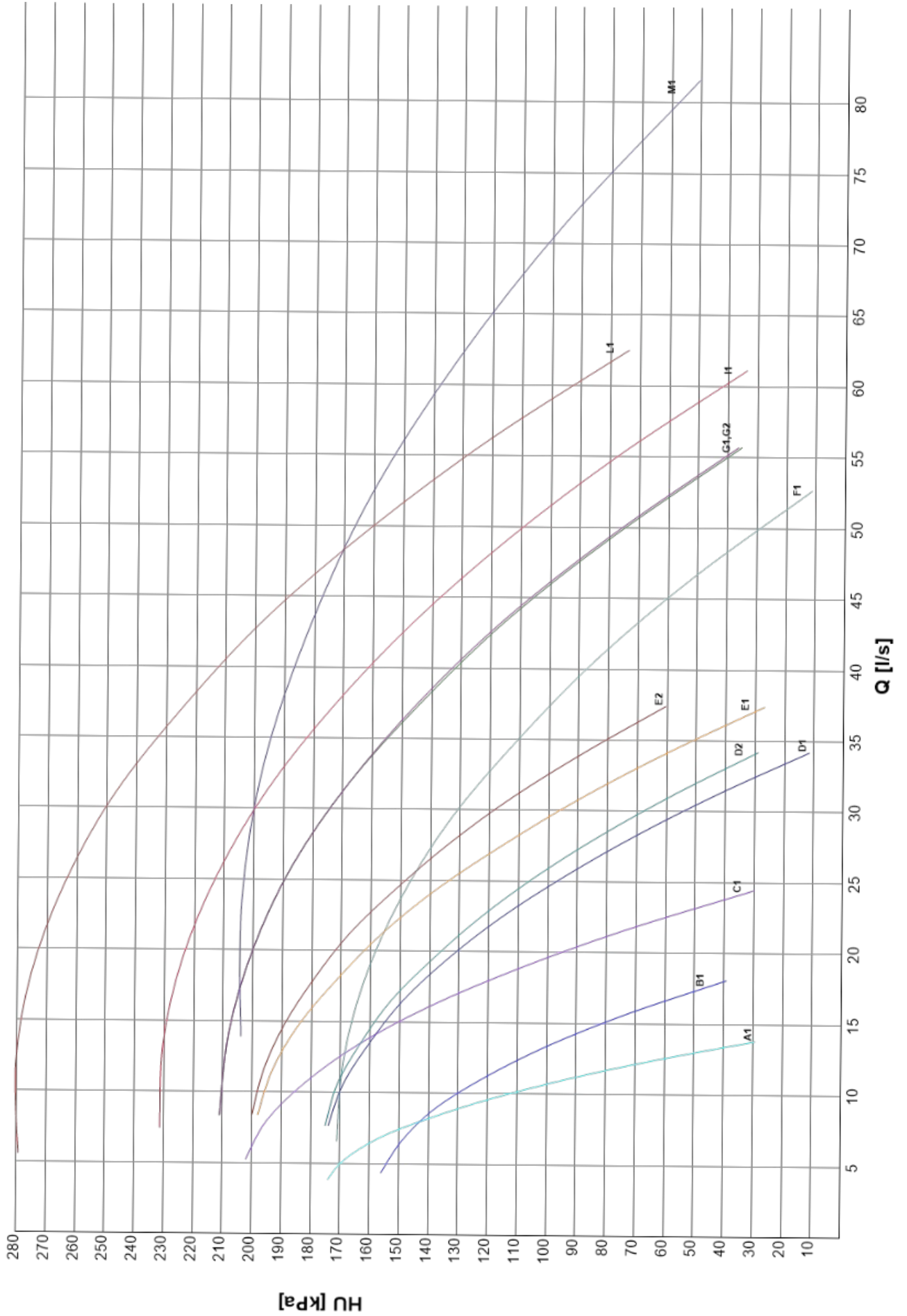

12.1 VARIABLE FLOW HYDRAULIC GROUP (optional)

12.2 VPF systems for plants designed with a single variable flow hydraulic circuit

The energy consumption associated with fluid circulation weighs heavily on the total operating costs of a large installation, especially when the units work at part load, and even more, when they are in stand-by. Under these conditions, although the power absorbed by the compressors and fans is reduced, the power consumed for water circulation remains high. The system power consumption can be reduced using pumps with continuous flow control by inverter. Energy savings are considerable and immediately evident, to the extent that a Δx reduction of the flow of water to be delivered to the system, amounts to a proportional reduction of $(\Delta x)^3$ in the power absorbed. In the most advanced systems these ones become the pumps for the entire hydraulic circuit, and this eliminates the need to detach the primary circuit, dedicated to the circulation of the water on the units side, from the secondary one, dedicated to water circulation throughout the entire system. In traditional systems it was the only choice possible and imposed mostly by the need for the chiller to work with constant water flow through the evaporator. Now designers can work without worrying about this limit, as Climaveneta units are designed to work with the maximum efficiency even with variable flow through the evaporator, managing the resources independently, in order to keep the outlet water temperature constantly at the set-point entered by the user. This simplifies the design and realization of variable flow systems and offers advantages in terms of both reductions in consumption and hydraulic circuit sizing. The integration of pumps + inverters built-in the unit permits significant savings in space, circuit components, and system start-up times.

The VPF (Variable Primary Flow system) is the Climaveneta solution that allows to have the variable water flow on the user side (evaporator) in the plants with primary circuit only.

The VPF kit includes the following devices:

- control device (called DP3 in the herebelow scheme), mounted on the electrical panel, and pressure differential transducer (with 4-20 mA signal), mounted on the heat exchanger user side
- control device (called PL3 in the herebelow scheme), positioned inside the electrical panel
- pumps with inverter and dedicated signals for the communication with the controller of the unit (W3000TE)

To these ones it's mandatory to add (not supplied by Climaveneta):

- pressure transducer on plant side, with the dedicated signal 4-20 mA for the communication with the PL3 device (this transducer must be installed on the longest (worst) leg of the installation)
- 2 way by-pass valve, with a dedicated 0-10V signal for the communication with the PL3 device

When the plant includes more units connected together with a management system (Manager 3000), it's mandatory to order also the option 3030 "VPF control from Manager 3000", in order to have the installation of the PL3 device inside the Manager itself and not in the electrical panel of each unit.

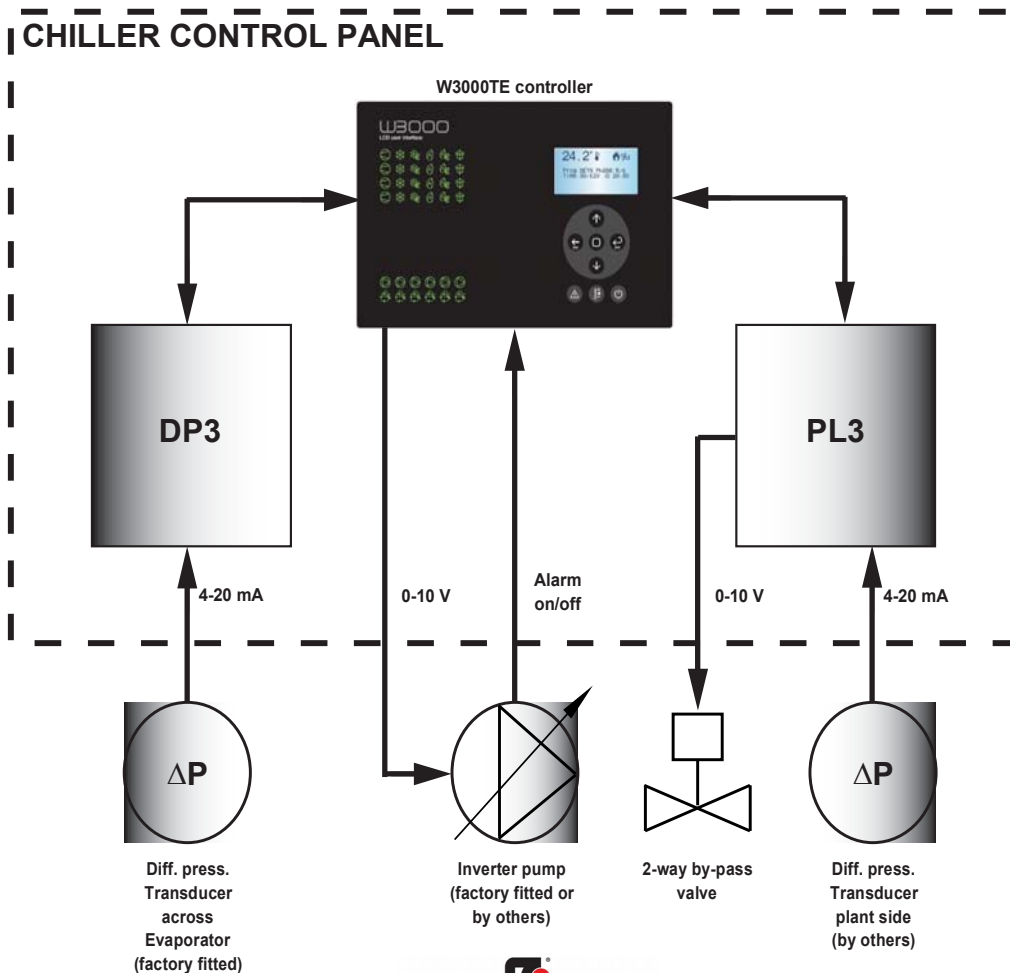

How it works

The VPF option measures the differential pressure across the installation in order to keep it between a minimum and a maximum value programmed in the PL3 device. As long as the measured value remains inside this range, the output signal to the pumps remains the same. On the other side when the measured value is bigger than the maximum programmed, the signal to the pumps is decreased, and in case the measured value results smaller than the minimum programmed, the signal to the pumps is increased. In any case the change of signal is performed through step by step adjustments and monitoring constantly the effects in order to avoid rough changes and guaranteeing the return of the measured value inside the programmed range as much quickly as possible.

In case the differential pressure requires a water flow smaller than the minimum necessary for the heat exchanger, the DP3 device communicates with the controller in the meantime that the PL3 send to the by-pass valve the signal to open gradually in order to protect the chiller.

When the plant includes more units, the working logic remains the same. The PL3 device, installed in the Manager, collects the information from the pressure transducer mounted in the plant (in common for all the units) and communicates with the by-pass valve (this one too in common for all the units), while the differential transducer mounted on each evaporator, the related DP3 device and the management of the pumps+inverters are duty of the W3000 of each unit.

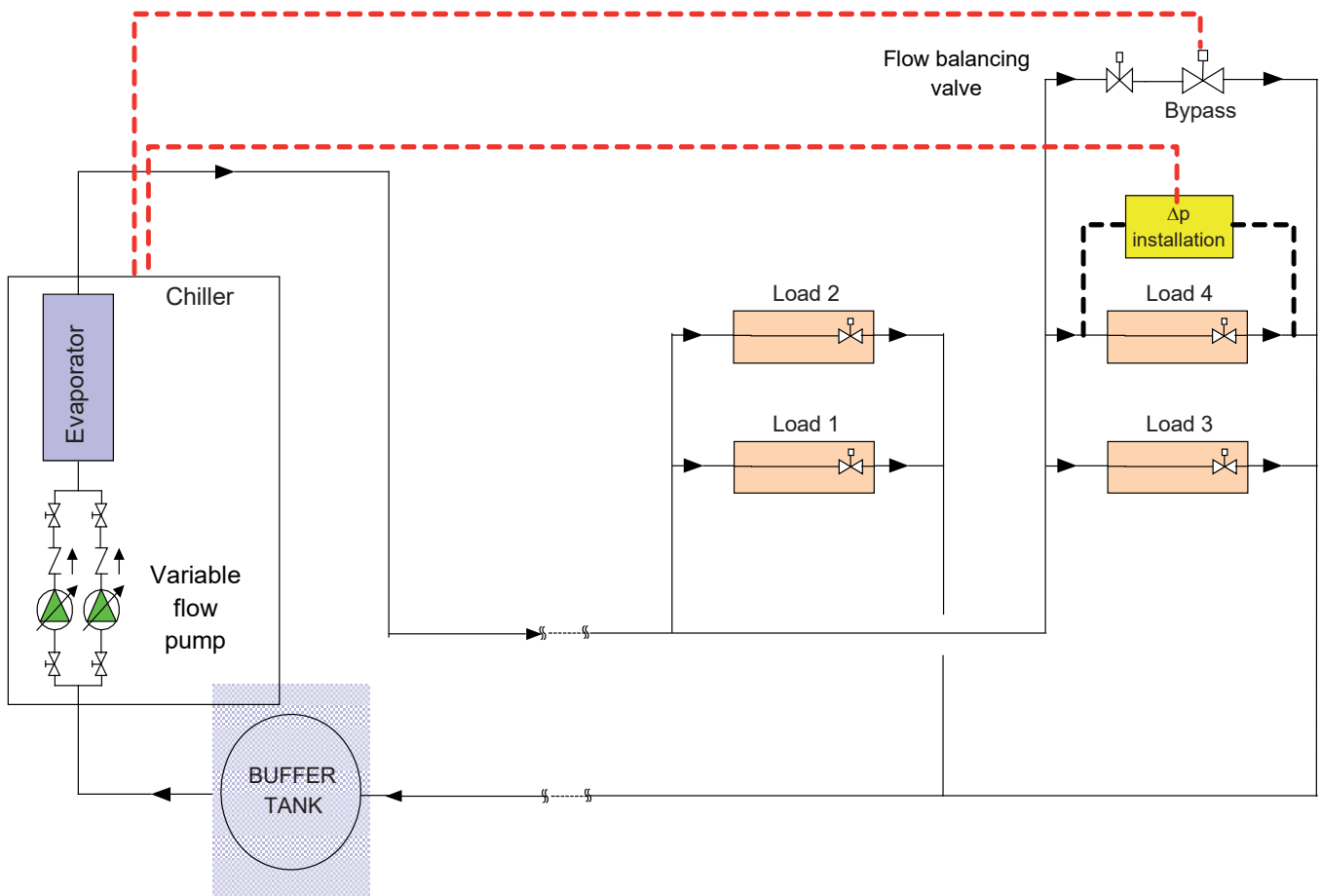

12.3 VPF.D systems for plants designed with both primary circuit and secondary one with variable flow

Also in those cases when it's not possible to design a single circuit with variable flow or when it's necessary to maintain decoupled the primary circuit (dedicated to the chillers) and the secondary one (dedicated to the plant users), it's possible to have the management of the pumps and inverters directly from the unit.

The energy savings are lower than the solution with a unique VPF system, but still important especially when the units are in stand-by, as in this case it's possible to reduce down to 50% the water flow.

These systems can be easily adopted in retrofit application, where the chiller is supposed to be replaced but the plant isn't. The Climaveneta solution guarantees also the water flow balancing between primary and secondary circuit, in order to avoid the flow inversion in the decoupling pipe.

The VPF.D system (Variable Primary Flow with Decoupler) is the option that allows to have variable water flow on the user side exchanger (evaporator) in plants with both primary and secondary circuits and additional pumps on the user side.

The VPF.D option includes:

- control device (PL3 in the herebelow scheme), mounted in the electrical panel
- 2 temperature probes, provided by Climaveneta but installed by the client in the plant, one for the delivery line and one for the by-pass line
- pumps with inverters and related signals for the communication with the controller W3000TE

When the plant includes more units connected together with a management system (Manager 3000), it's mandatory to order also the option 3030 "VPF control from Manager 3000", in order to have the installation of the PL3 device inside the Manager itself and not in the electrical panel of each unit.

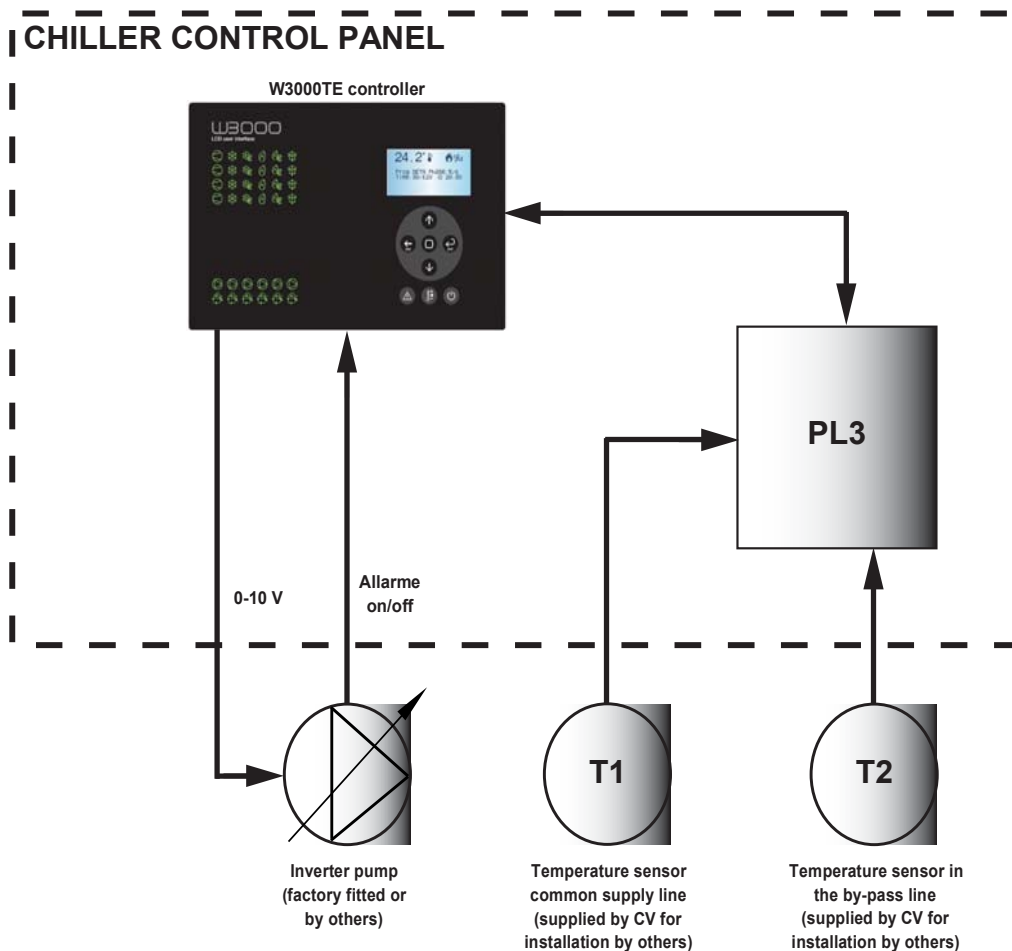

How it works

The VPF. D measures, through the two probes installed, the temperatures T1 and T2 (on the delivery and by-pass lines), keeping $T2=T1$ as control target.

As long as $T1=T2$, the water flow in the primary circuit is equal or higher than in the secondary one. When $T2>T1$, the water flow in the primary circuit becomes lower than the flow in the secondary circuit, leading to recirculation of warm water coming back from the installation and mixing with the cold supply water.

In order to rebalance this situation the speed of the pumps is being increased gradually in order to let the temperature T1 be again equal to T2.

The target of the VPF.D is then to keep constant the ΔT in the primary circuit. The secondary circuit remains completely independent and so has to be managed and controlled by the customer side.

The minimum water flow through the user side exchanger is guaranteed by a fixed setting for the minimum speed of the pumps (inside the service menu of the unit controller).

When the plant includes more units, the working logic remains the same. The PL3 device, installed in the Manager, collect the information about temperatures T1 and T2, while the W3000 of each unit takes care of the speed of the pumps, according to the signal sent from the Manager. The Manager itself takes care also that the pumps of each chiller work at the same speed and that, when an additional unit is switched on, the speed of the already running pumps is automatically aligned

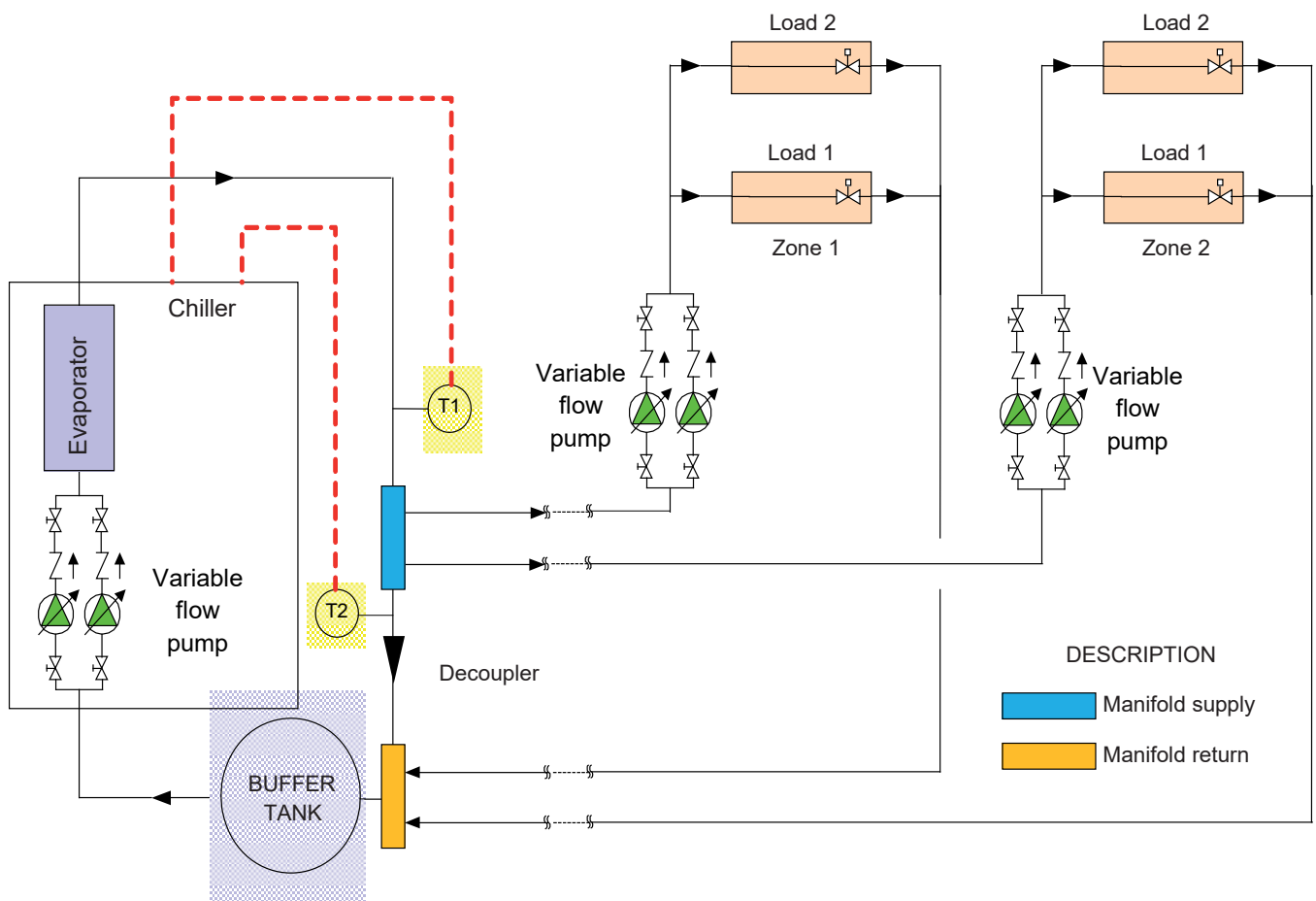



for a greener tomorrow

Eco Changes is the Mitsubishi Electric Group's environmental statement, and expresses the Group's stance on environmental management. Through a wide range of businesses, we are helping contribute to the realization of a sustainable society.



mitsubishi electric hydronics & it cooling systems S.p.A.

Head Office: Via Roma 5 • 27010 Valle Salimbene (PV) • Italy
Ph. (+39) (0) 382 433 811 • Fax (+39) (0) 382 587148

www.rcitcooling.com
www.melcohit.com